

Steca Elektronik

**INVERTER / CHARGER WITH MPPT: SOLARIX PLI**



# INVERTER SYSTEMS

## SOLARIX PLI 5000-48



- Inverter / Charger with MPPT charge controller
- All-in-one:
  - 5 kW / 5 kVA pure sine wave inverter (10 kW / 10 kVA up to 5 s)
  - 80 A MPPT charge controller (max. 145 Voc)
  - 60 A charger from AC source (grid or generator)
  - *Additionally only fuses and surge protector are required in most systems*
- Usable off-grid and on-grid (no grid injection)
- Usable with generator (automatic generator start)
- Solar or grid / generator priority selectable
- Synchronised to grid and fast UPS switching (10 ms)
- Overload bypass to grid selectable
- Very light: 11.5 kg

# INVERTER SYSTEMS

## SOLARIX PLI 2400-24



- Inverter / Charger with MPPT charge controller
- All-in-one:
  - 2.4 kW / 3.0 kVA pure sine wave inverter (4.8 kW / 6.0 kVA up to 5 s)
  - 40 A MPPT charge controller (max. 100 Voc)
  - 60 A charger from AC source (grid or generator)
  - *Additionally only fuses and surge protector are required in most systems*
- Usable off-grid and on-grid (no grid injection)
- Usable with generator (automatic generator start)
- Solar or grid / generator priority selectable
- Synchronised to grid and fast UPS switching (10 ms)
- Overload bypass to grid selectable
- Very light: 7.6 kg

# INVERTER SYSTEMS

## SOLARIX PLI 1000-12



- Inverter / Charger with MPPT charge controller
- All-in-one:
  - 1 kW / 1 kVA pure sine wave inverter (2 kW / 2 kVA up to 5 s)
  - 40 A MPPT charge controller (max. 100 Voc)
  - 20 A charger from AC source (grid or generator)
  - *Additionally only fuses and surge protector are required in most systems*
- Usable off-grid and on-grid (no grid injection)
- Usable with generator (automatic generator start)
- Solar or grid / generator priority selectable
- Synchronised to grid and fast UPS switching (10 ms)
- Overload bypass to grid selectable
- Very light: 6.9 kg

# INVERTER SYSTEMS

## SOLARIX PLI

Example: off-grid system

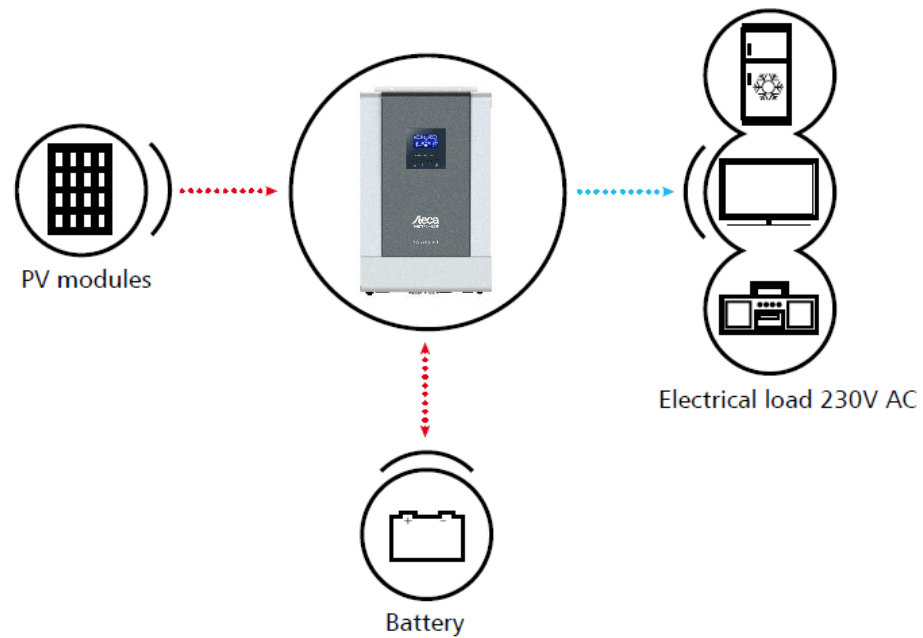

- Pure off-grid system (no AC input)
- PV as only energy source

# INVERTER SYSTEMS

## SOLARIX PLI

Example: uninterruptible power supply

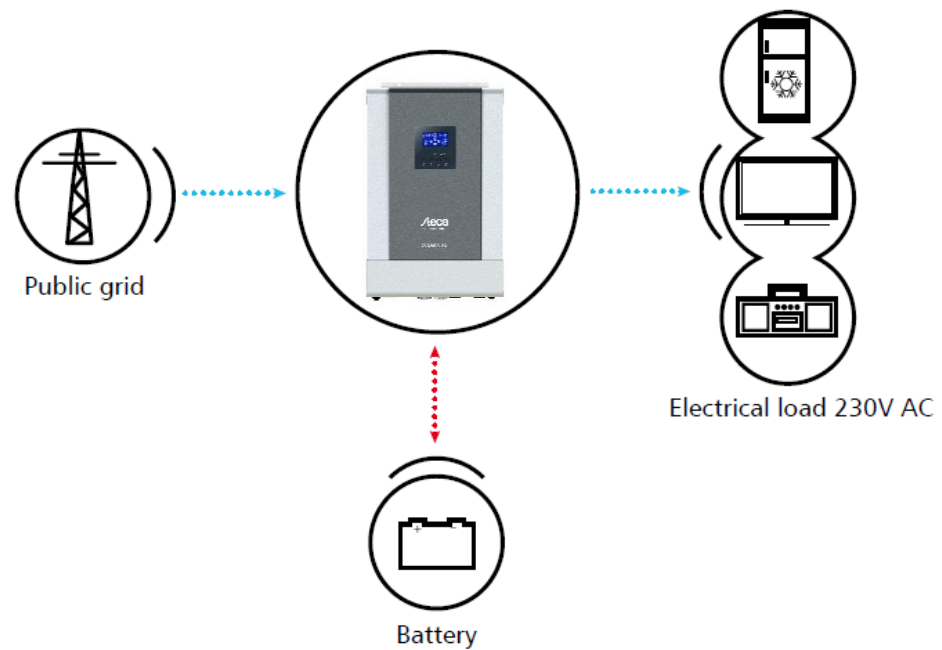

- Pure on-grid system
- No PV as only energy source, only grid
- Battery is charged from the grid whenever the grid is available
- Useful when grid fails as backup (10 ms switchover time)

# INVERTER SYSTEMS

## SOLARIX PLI

Example: solar priority with grid connection

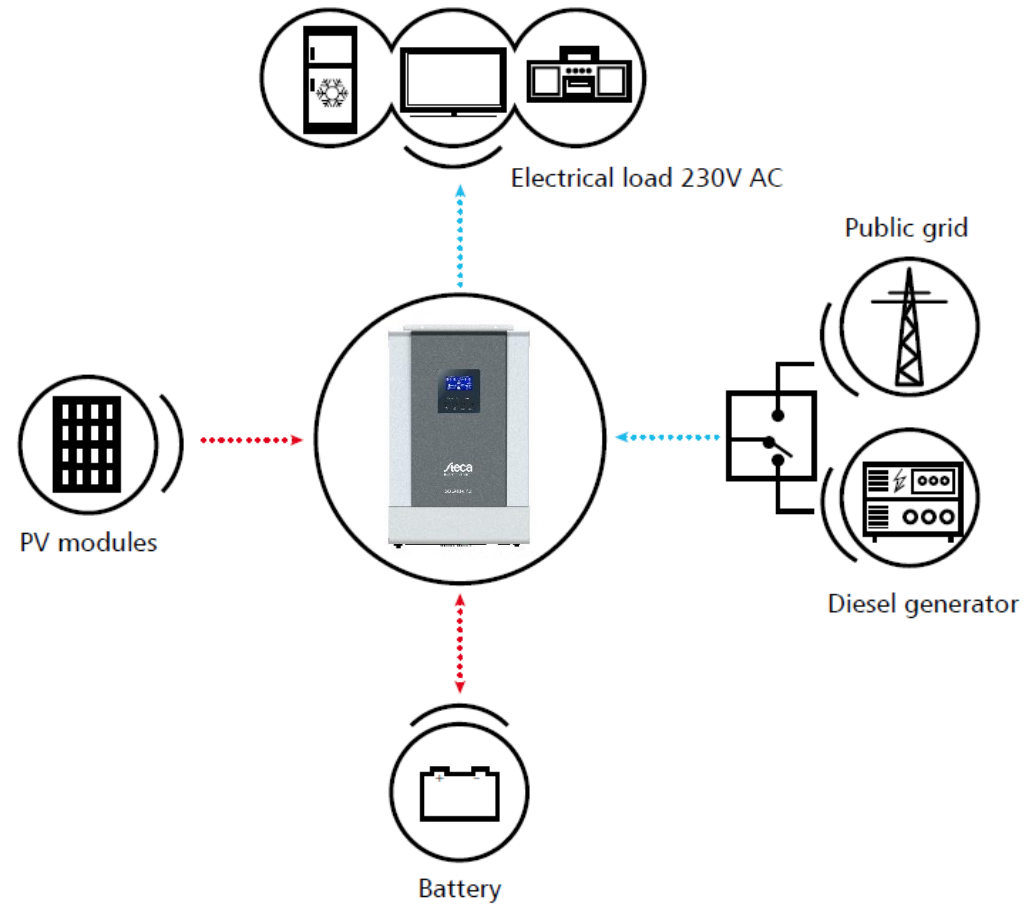

- Grid-connected system or off-grid with AC generator (external source selector required if both are used)
- PV is priority, alternatively grid / generator can be selected as priority
- Optional charging from the grid / generator

# INVERTER SYSTEMS

## SOLARIX PLI

Shown values:

- AC input / output voltage (default view)
- AC input / output frequency
- PV voltage
- Charging / discharging current
- Charging power
- Battery voltage
- Load VA / Watt / % of nominal inverter power (with overload icon)
- Battery diagram for state-of-charge approximation and charging status
- Settings menu
- Warning / fault codes
- Alarm muted
- Energy path diagram examples:

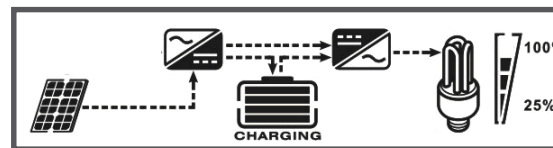

PV charging with inverter on

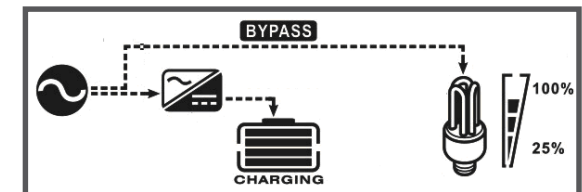
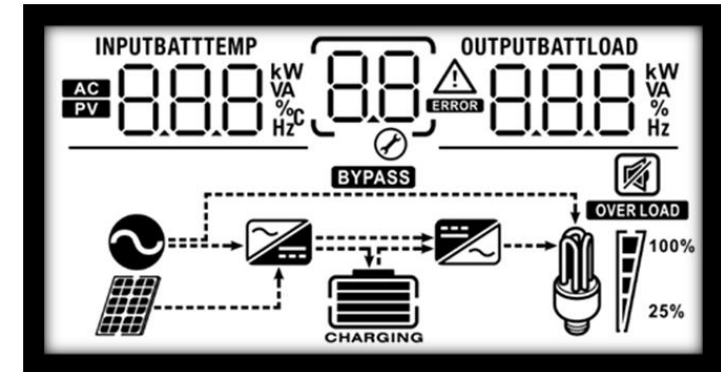

Grid charging with by-pass mode active



# INVERTER SYSTEMS

## SOLARIX PLI

### Energy source priorities

- Solar → Battery → AC input / utility (SBU)

1. PV supplies the loads first
2. If PV power is insufficient, the battery supplies the remaining energy
3. When the battery reaches its programmable lower battery limit (not the same as low-voltage disconnect), the AC input is used to supply the loads entirely

#### Use-case:

- Maximum reduction of grid power consumption by utilising PV and the battery capacity to their fullest extent.

- AC input first (utility grid)

1. Whenever a valid AC input source is present, it is used first
2. When no valid AC input source is available, power to the loads is supplied by PV and the battery

#### Use-case:

- Classic uninterruptible power supply: use the AC input / grid when possible. When the grid fails, supply the loads from PV and battery.

- Solar first

1. PV supplies the loads first
2. If PV power is insufficient (but available), the battery supplies the remaining energy
3. When the battery reaches its programmable lower battery limit (not the same as low-voltage disconnect) or when there is no PV energy available (0 Watts), the AC input is used to supply the loads entirely

#### Use-case:

- Reduction of grid power consumption by utilising PV to its fullest extent, but limiting battery cycling. During the night, when no PV power is available, the Solarix PLI will only supply loads from the AC input (unless the AC input / grid fails, then the battery will supply the loads).

# INVERTER SYSTEMS

## SOLARIX PLI 5000-48

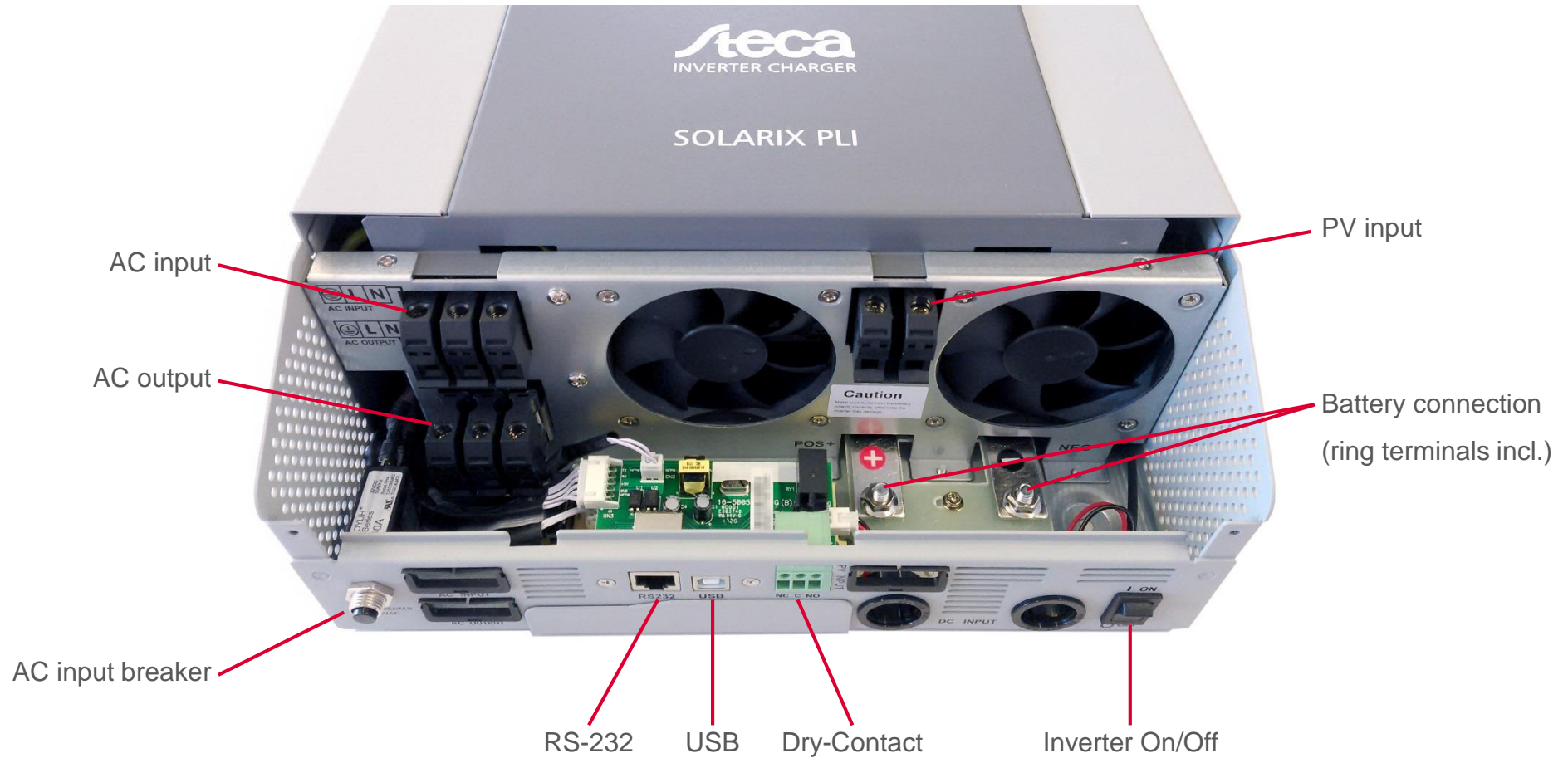

Note: MPPT charge controller always remains on, regardless of switch position

# INVERTER SYSTEMS

## SOLARIX PLI 2400-24

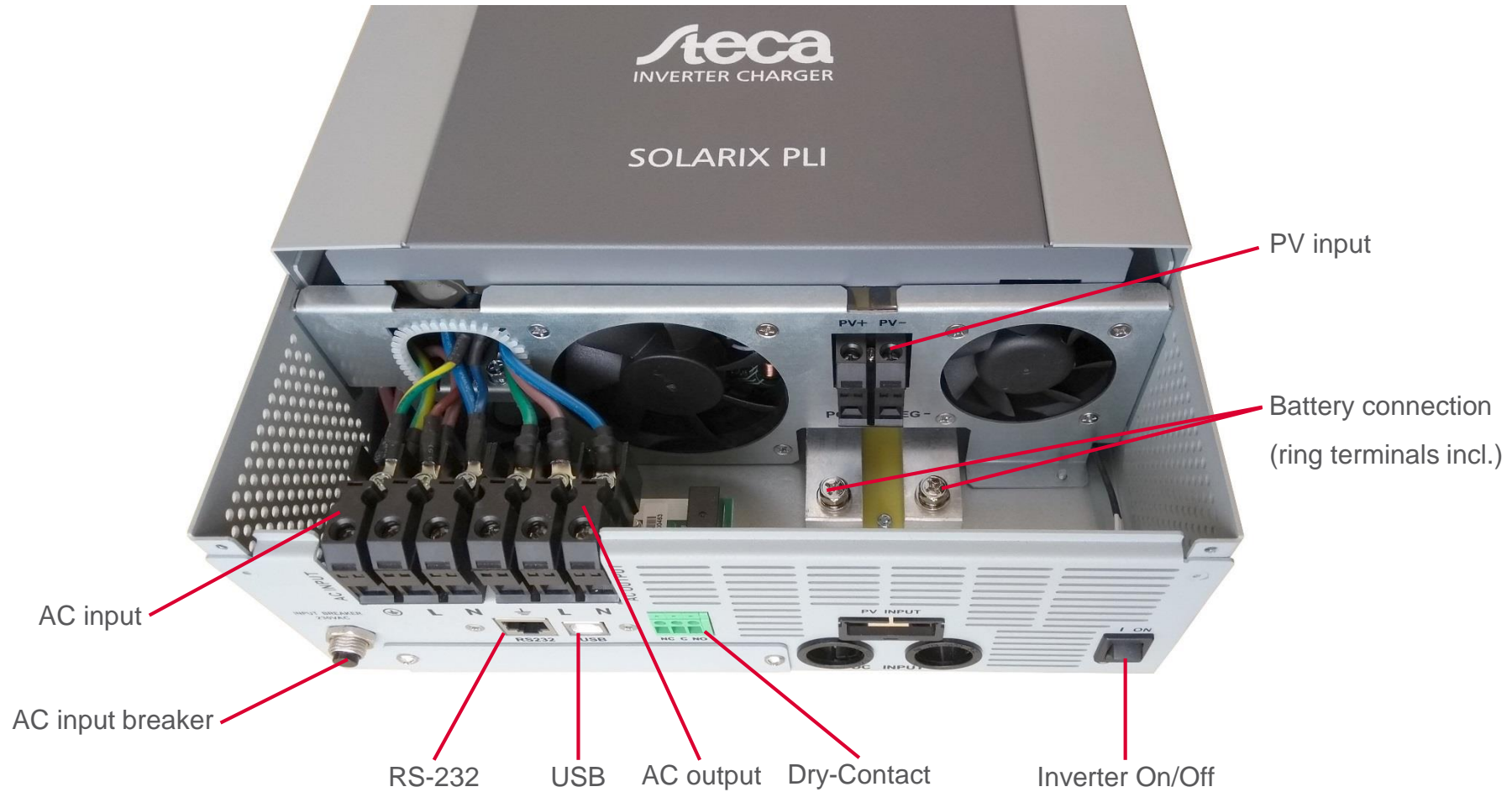

Note: MPPT charge controller always remains on, regardless of switch position

# INVERTER SYSTEMS

## SOLARIX PLI

Parallel / 3-phase kit: only for PLI 5000-48 and PLI 2400-24

- Parallel Kit to extend Solarix PLI systems: one kit is required for each connected Solarix PLI
- Up to 9 Solarix PLI can be connected together:
  - Maximum 45 kW (9 x 5 kW) = 9 pcs. Solarix PLI 5000-48 per system  
Maximum 21.6 kW (9 x 2.4 kW) = 9 pcs. Solarix PLI 2400-24 per system
  - Maximum 9 pcs. Solarix PLI on one phase

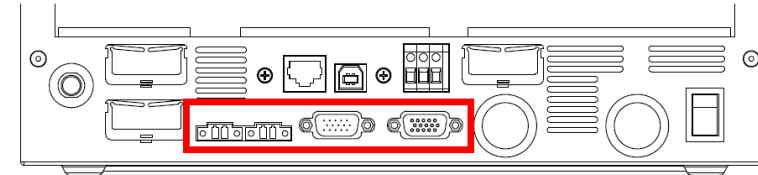

Installed Parallel Board (PLI 5000-48)

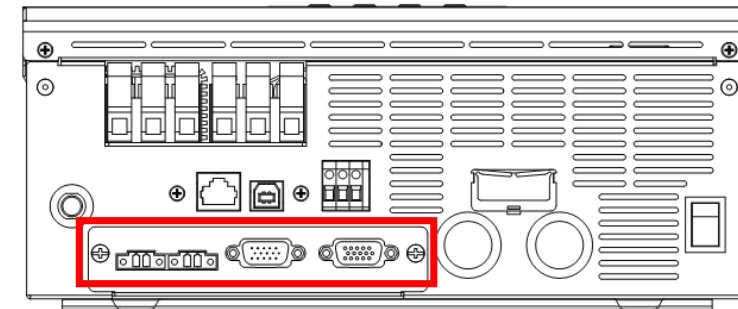

Installed Parallel Board (PLI 2400-24)

Parallel Kit contents:

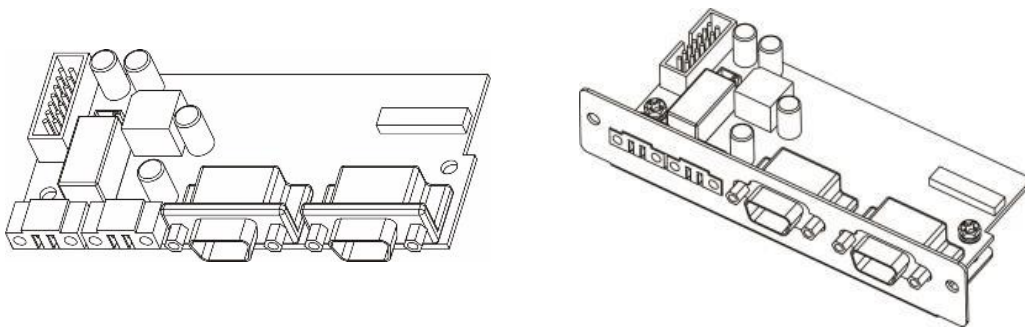

Parallel Board PLI 5000-48

or

Parallel Board PLI 2400-24

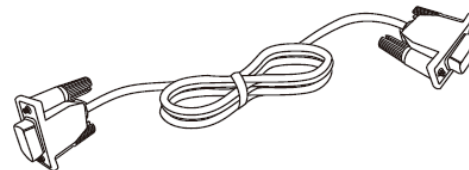

Communication Cable



Current Sharing Cable

# INVERTER SYSTEMS

## SOLARIX PLI

### Parallel connection

- Example: 3x Solarix PLI on one phase
- Up to 9x PLI on one phase possible

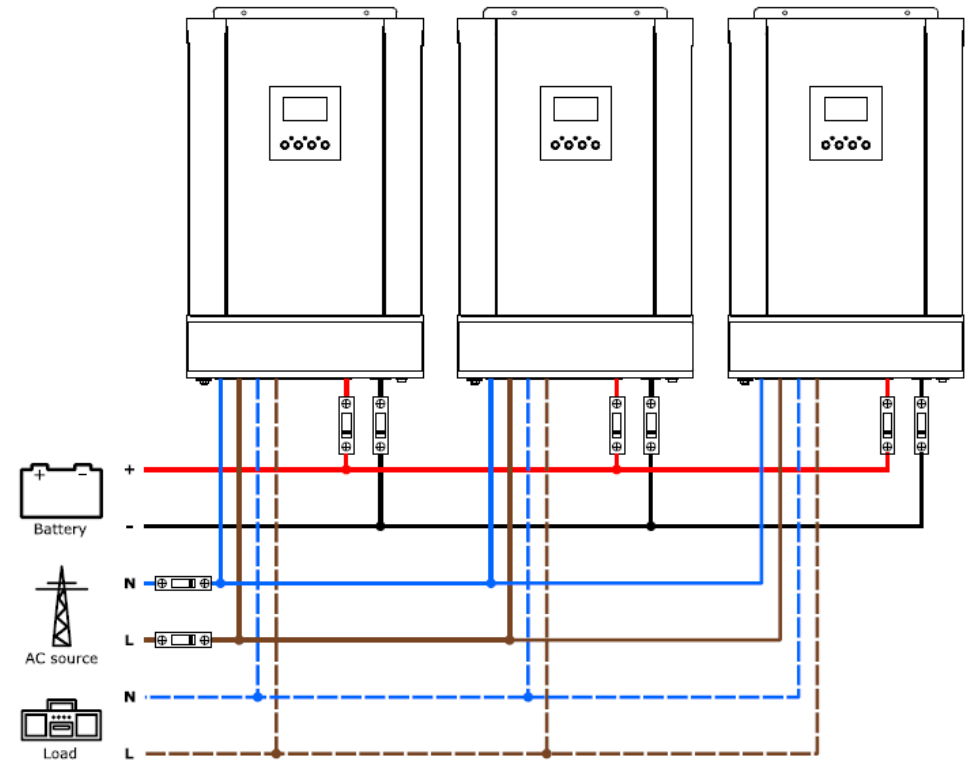

Communication and Current Sharing Cables (included in kit):

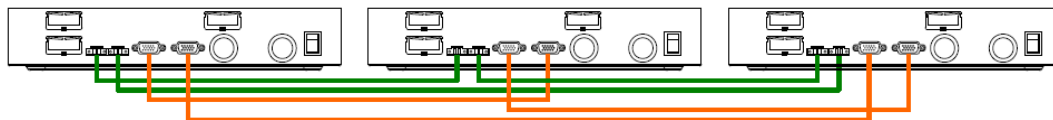

# INVERTER SYSTEMS

## SOLARIX PLI

### 3-phase connection

- Example: 3x Solarix PLI, one on each phase
- At least one PLI per phase, up to 7x PLI on one phase possible

Communication and Current Sharing Cables:

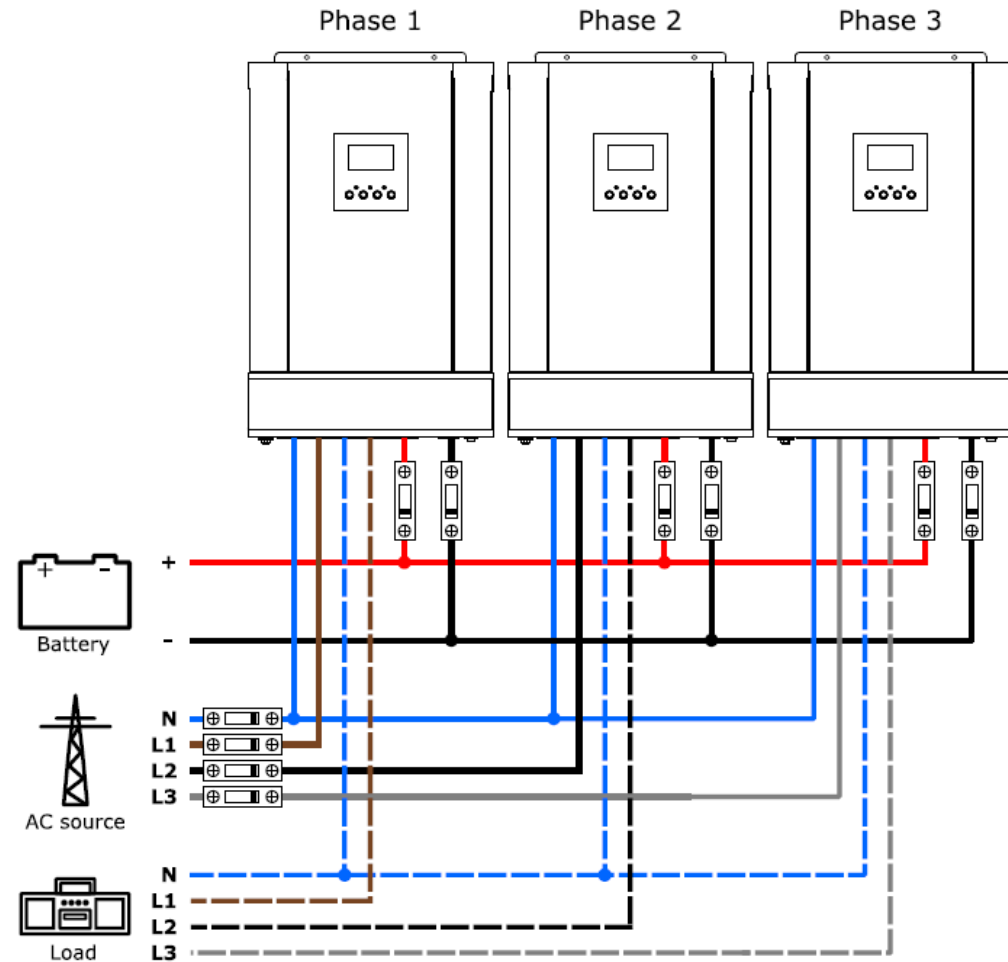
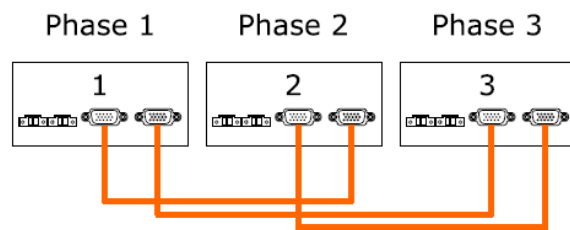

# INVERTER SYSTEMS

## SOLARIX PLI

### 3-phase connection

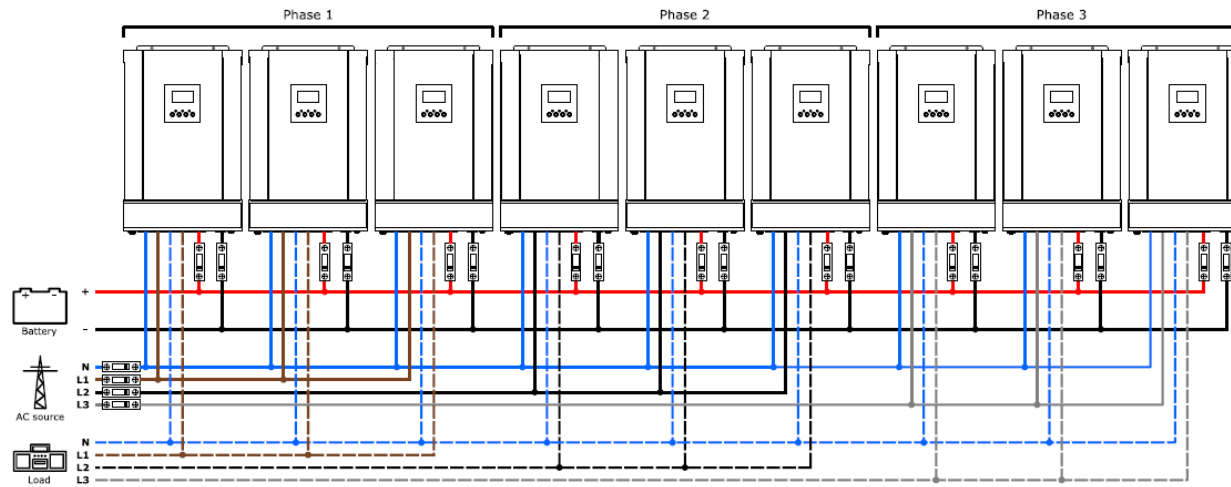

← Example: 3x PLI per phase

Example: 3x PLI on L1 + 2x PLI on L2 + 1x PLI on L3 →

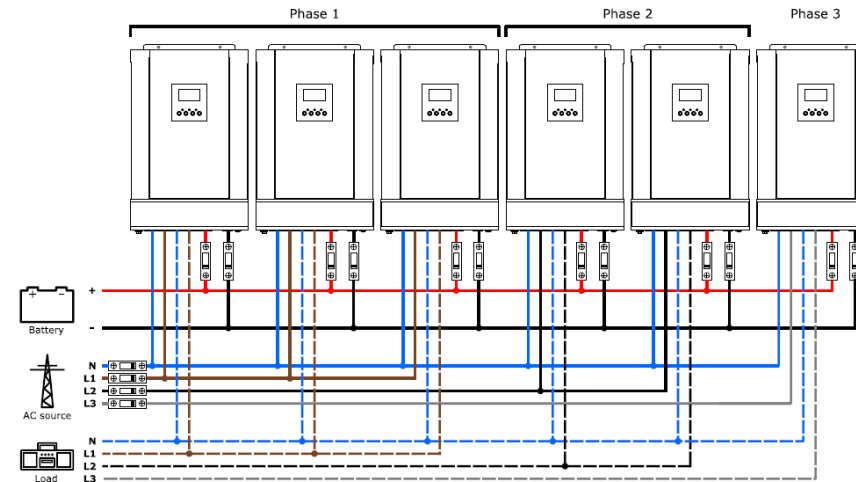

# INVERTER SYSTEMS

## SOLARIX PLI 5000-48 AND PLI 2400-24

Block diagram

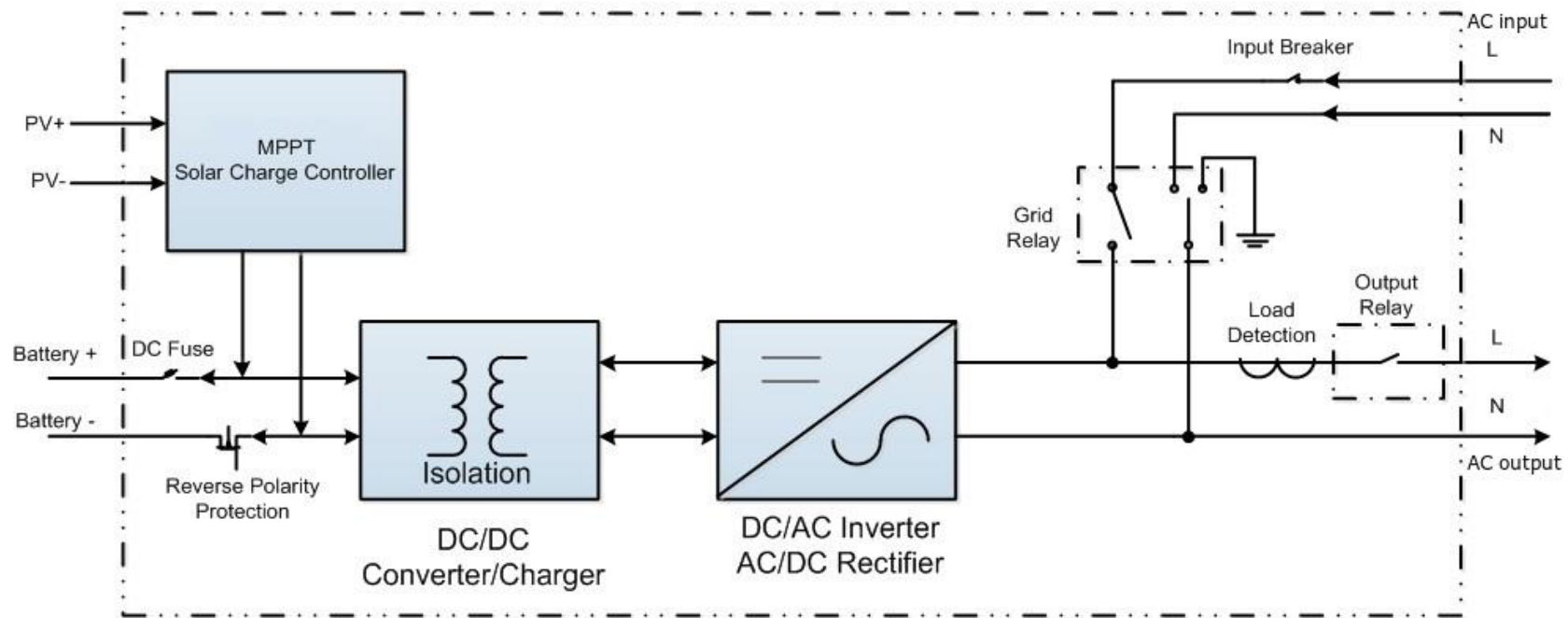



# INVERTER SYSTEMS

## SOLARIX PLI 1000-12

Block diagram

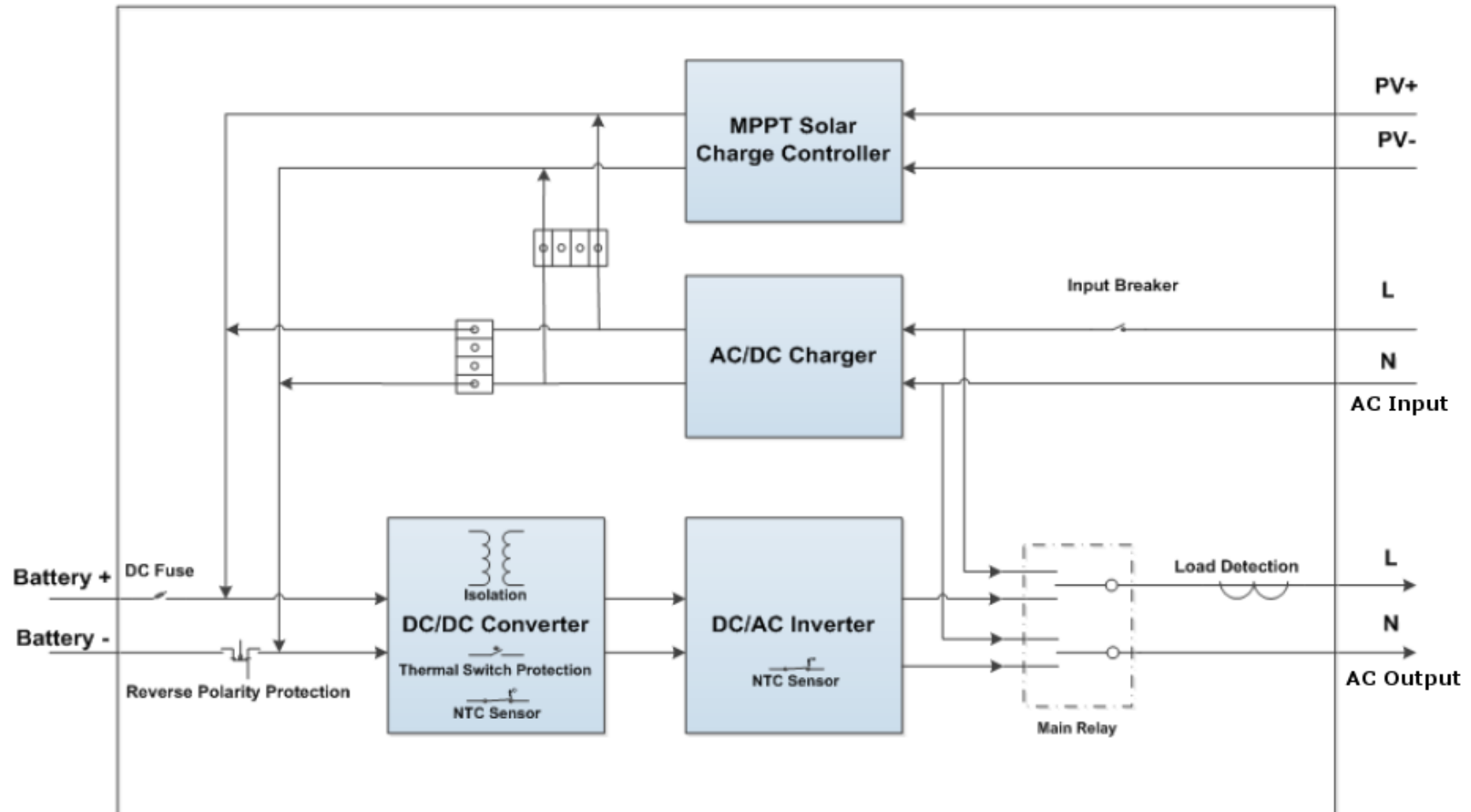

# INVERTER SYSTEMS

## SOLARIX PLI

### PV grounding

- It is possible (but not necessary) to ground the positive PV cable, if so required by the PV module manufacturer

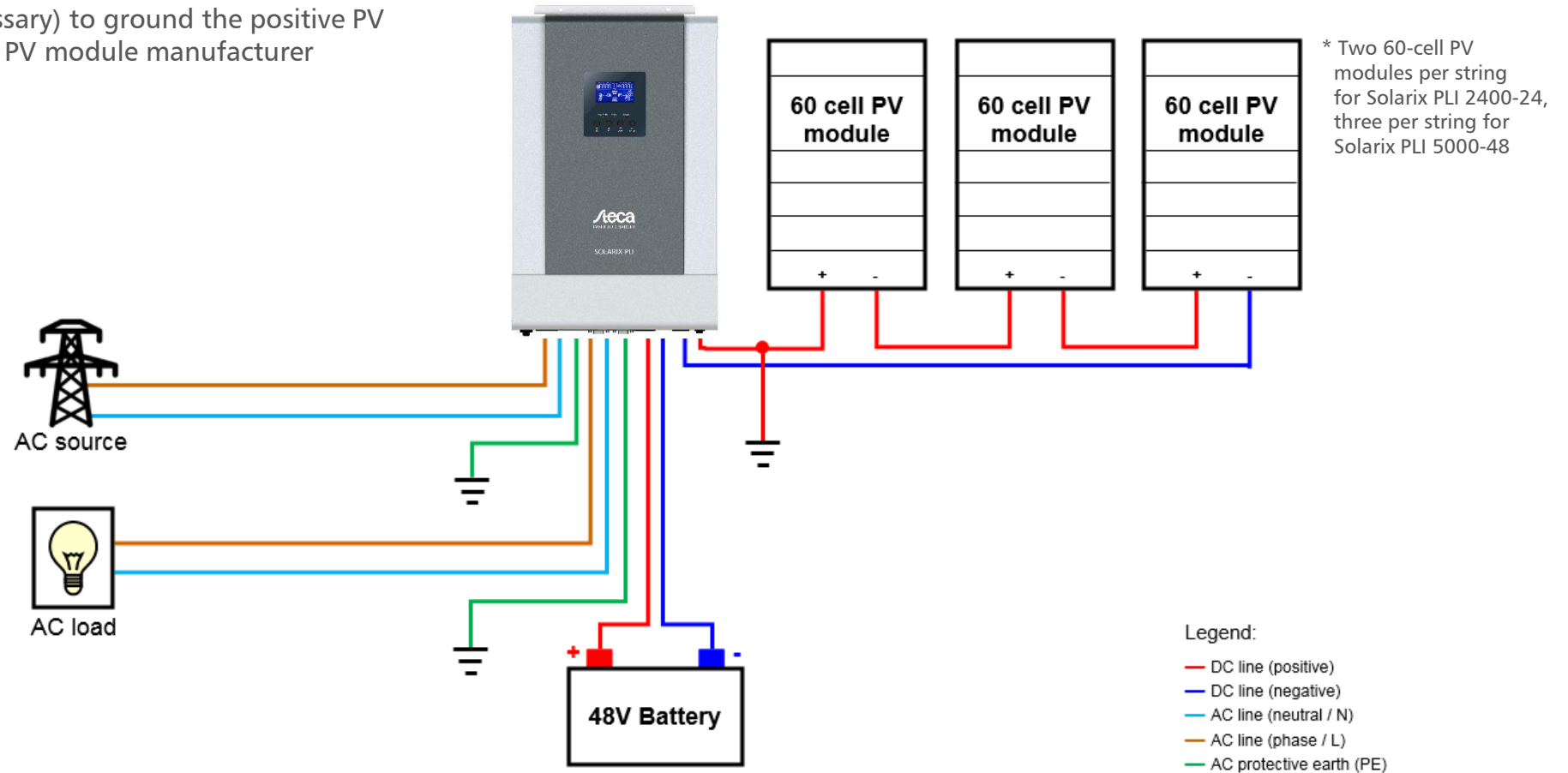

# INVERTER SYSTEMS

## SOLARIX PLI

### PV grounding

- It is possible (but not necessary) to ground the negative PV cable, if so required by the PV module manufacturer

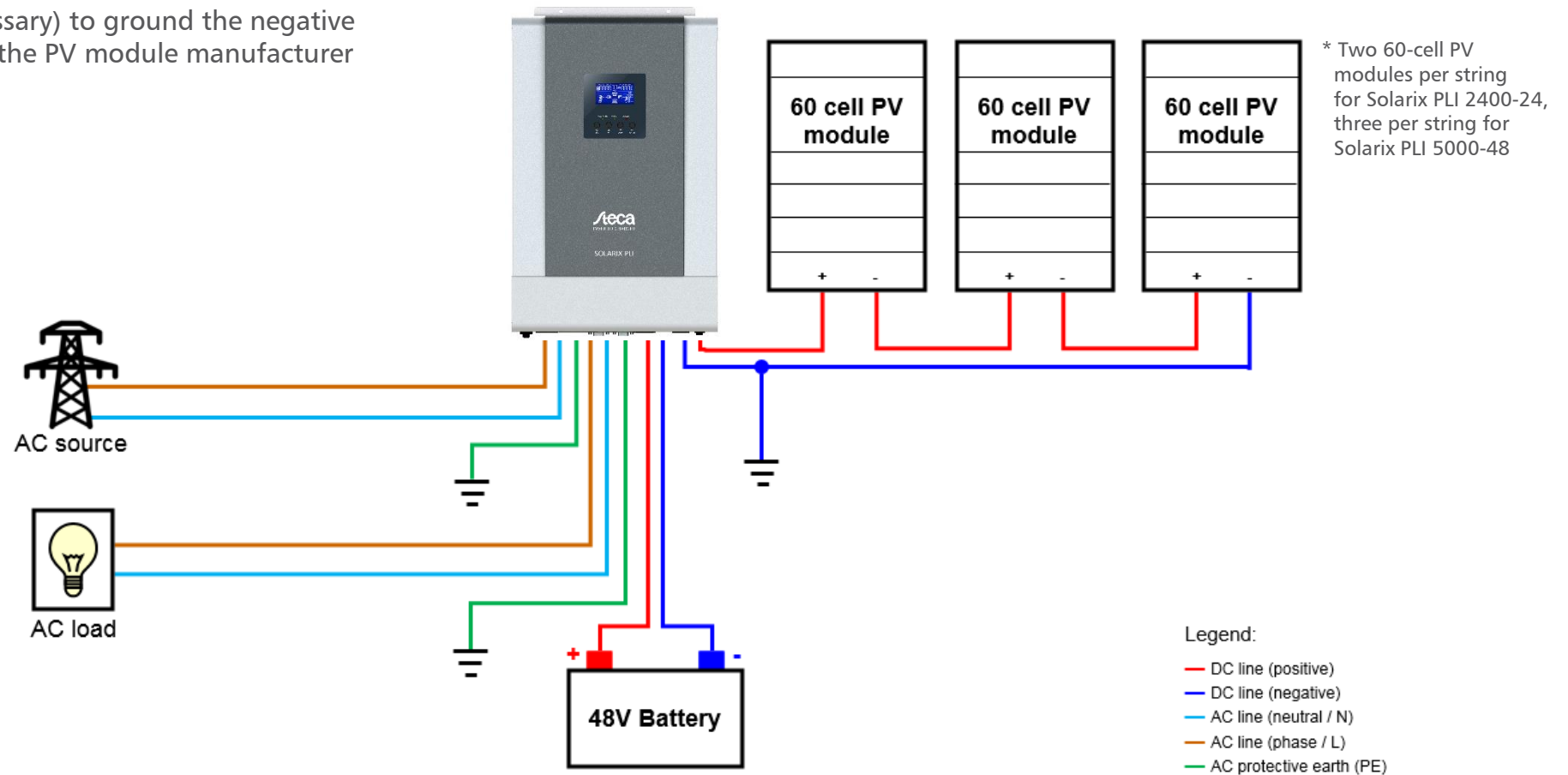

# INVERTER SYSTEMS

## SOLARIX PLI

### Battery grounding

- It is possible (but not necessary) to ground the **positive** terminal of the battery

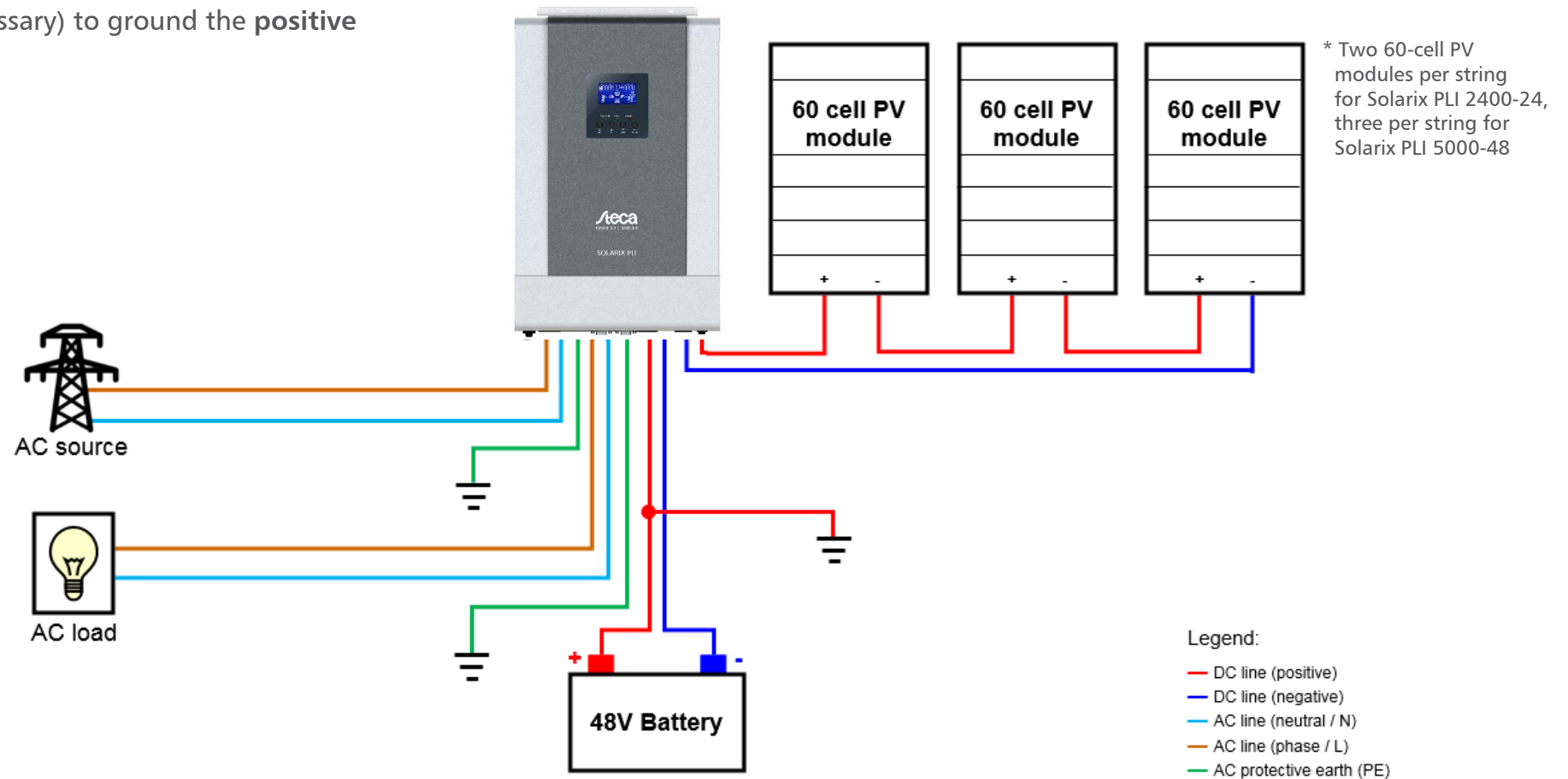

# INVERTER SYSTEMS

## SOLARIX PLI

### Battery grounding

- It is possible (but not necessary) to ground the **negative** terminal of the battery

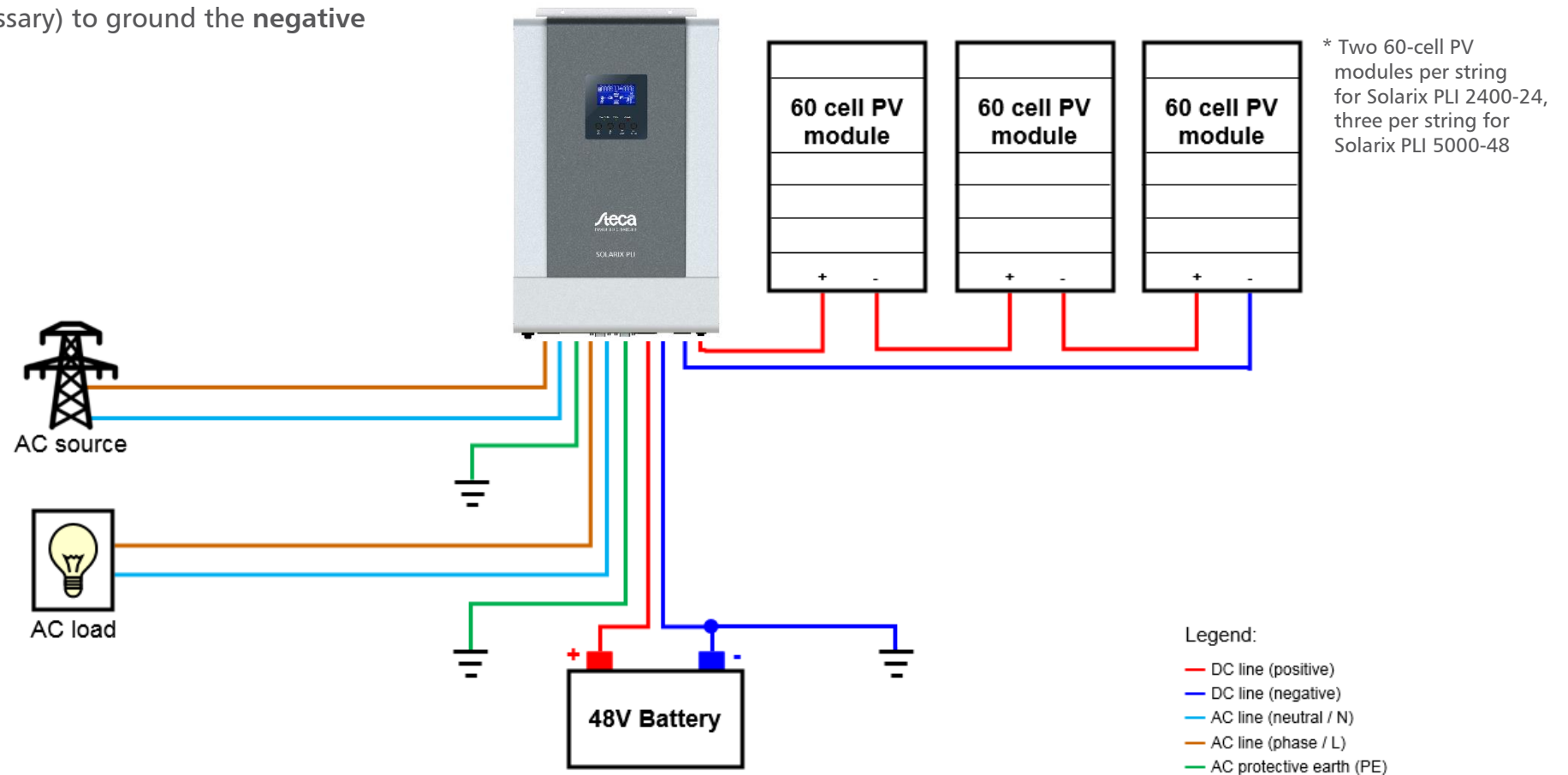

# INVERTER SYSTEMS

## SOLARIX PLI

### Battery and PV grounding

- It is possible (but not necessary) to ground the negative terminal of both the PV cables and the battery.

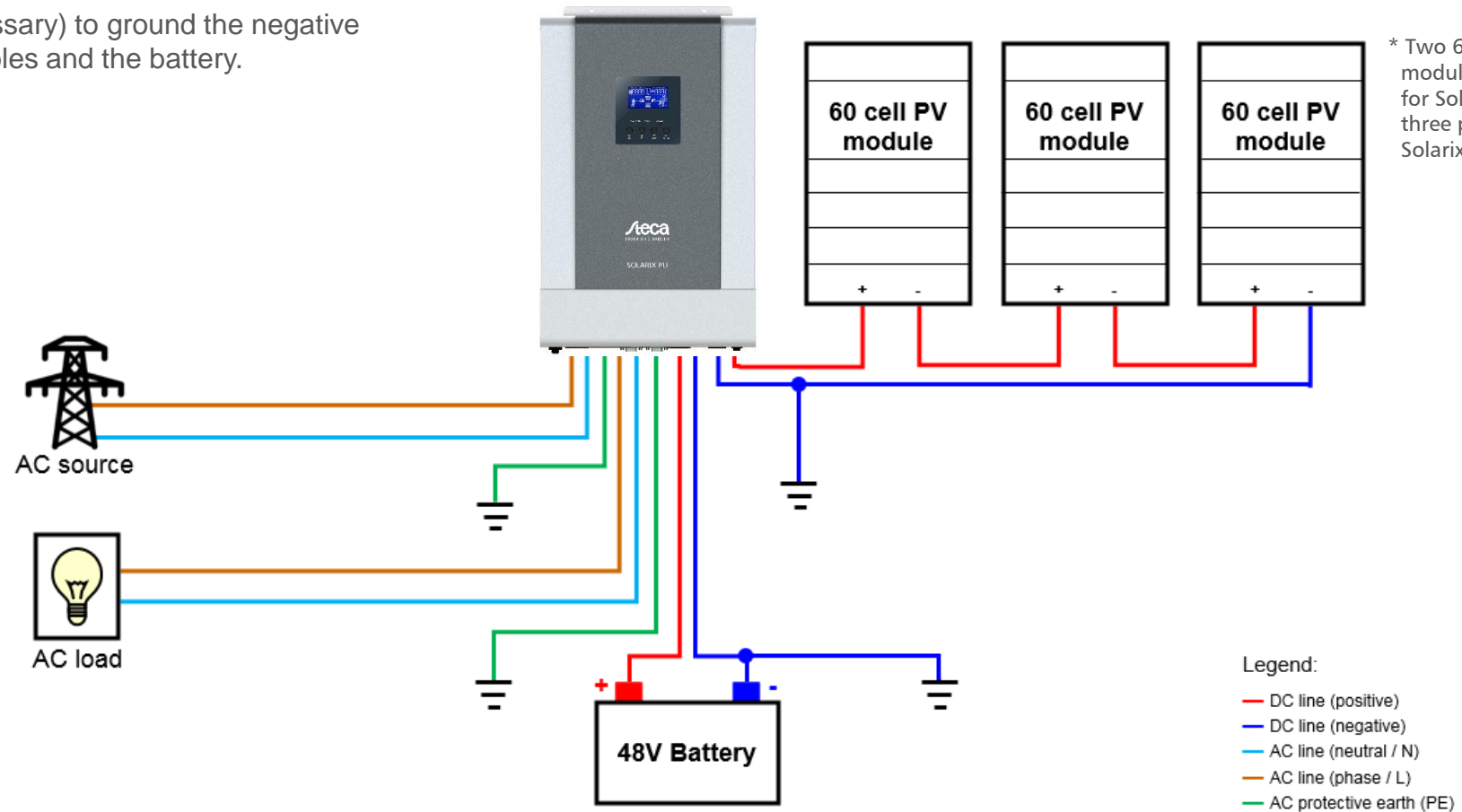

### Battery and PV grounding

What type of battery / PV grounding is not possible?

- It is **not** permitted to ground a PV cable and the opposite polarity of the battery terminal at the same time
- It is **not** permitted to ground the positive PV cable and the positive battery terminal at the same time

### AC grounding & operator protection

- It is necessary to ground the PE (protective earth) terminals of the AC input and AC output of the Solarix PLI
- When the Solarix PLI is running in inverter / battery mode (disconnected from the AC input), neutral (N) is automatically tied to PE, therefore a residual current device (RCD) will function between the AC output and the loads in this mode
- Take advantage of the automatic N to PE bridging of the inverter, allowing the use of a low-cost RCD



# INVERTER SYSTEMS

## SOLARIX PLI

### AC grounding & operator protection: automatic N to PE bridging

- N and PE (protective earth) are automatically bridged when the inverter operates in off-grid mode so that an RCD will function between the inverter and the AC loads
- Reliable protection with comparatively cheap RCD

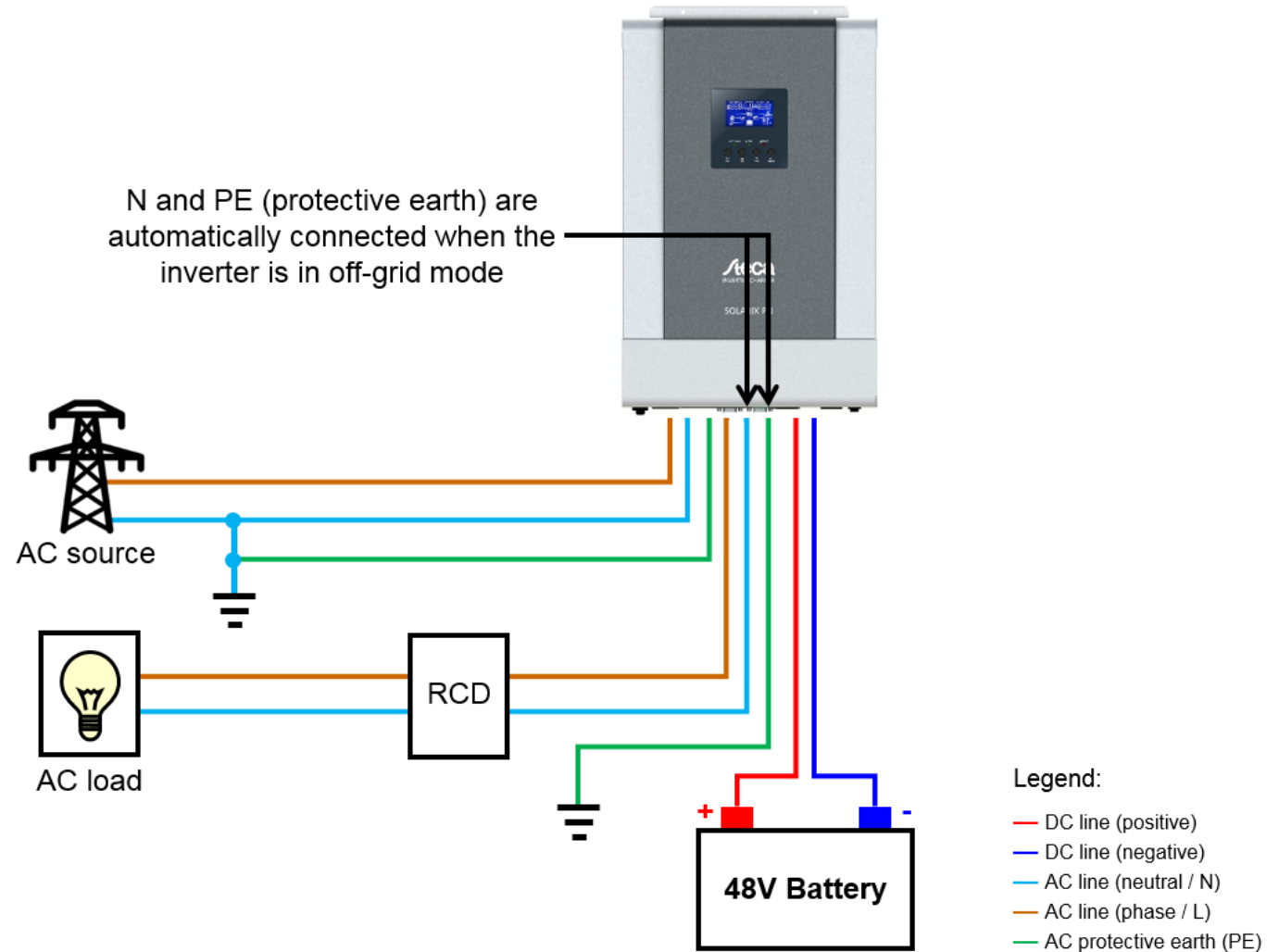

# INVERTER SYSTEMS

## SOLARIX PLI 5000-48

### PV sizing example for Solarix PLI 5000-48

Relevant PV module information:

- Total power of PV modules (in Wp)
- Voltage of PV modules ( $U_{mpp}$  and  $U_{oc}$ )



# INVERTER SYSTEMS

## SOLARIX PLI

### PV sizing example

- The minimum voltages:
  - For Solarix PLI 5000-48 systems the PV voltage should be 68 Vmpp or higher
  - For Solarix PLI 2400-24 systems the PV voltage should be 34 Vmpp or higher
- The absolute maximum voltages under all temperature conditions (check the temperature coefficient of your PV modules) :
  - 145 Voc (115 Vmpp) for the Solarix PLI 5000-48
  - 100 Voc (80 Vmpp) for the Solarix PLI 2400-24 and Solarix PLI 1000-12
- Recommendations:
  - For 36-cell crystalline modules use **5** modules in series per string for Solarix PLI 5000-48  
For 36-cell crystalline modules use **3** modules in series per string for Solarix PLI 2400-24 or Solarix PLI 1000-12  
alternatively use **2** 36-cell crystalline modules in series per string for Solarix PLI 1000-12
  - For 60-cell crystalline modules use **3** modules in series per string for Solarix PLI 5000-48  
For 60-cell crystalline modules use **2** modules in series per string for Solarix PLI 2400-24 or Solarix PLI 1000-12  
alternatively use **1** 60-cell crystalline module per string for Solarix PLI 1000-12
  - For 72-cell crystalline modules use **2** modules in series per string for Solarix PLI 5000-48  
For 72-cell crystalline modules use **1** module in series per string for Solarix PLI 2400-24 or Solarix PLI 1000-12

Note: 72-cell crystalline modules are **not recommended** for the Solarix PLI 2400-24 in many cooler climates

# INVERTER SYSTEMS

## SOLARIX PLI 5000-48

### PV sizing example for Solarix PLI 5000-48

- PV module specifications:
  - 250 Wp modules (60 cells)
  - $U_{mpp} = 31.2V$
  - $U_{oc} = 37.6V$
  - $I_{sc} = 8.5A$
- Battery voltage 48 V, maximum usable power 4800 W
- String fuses are likely required when using more than 2 strings in parallel

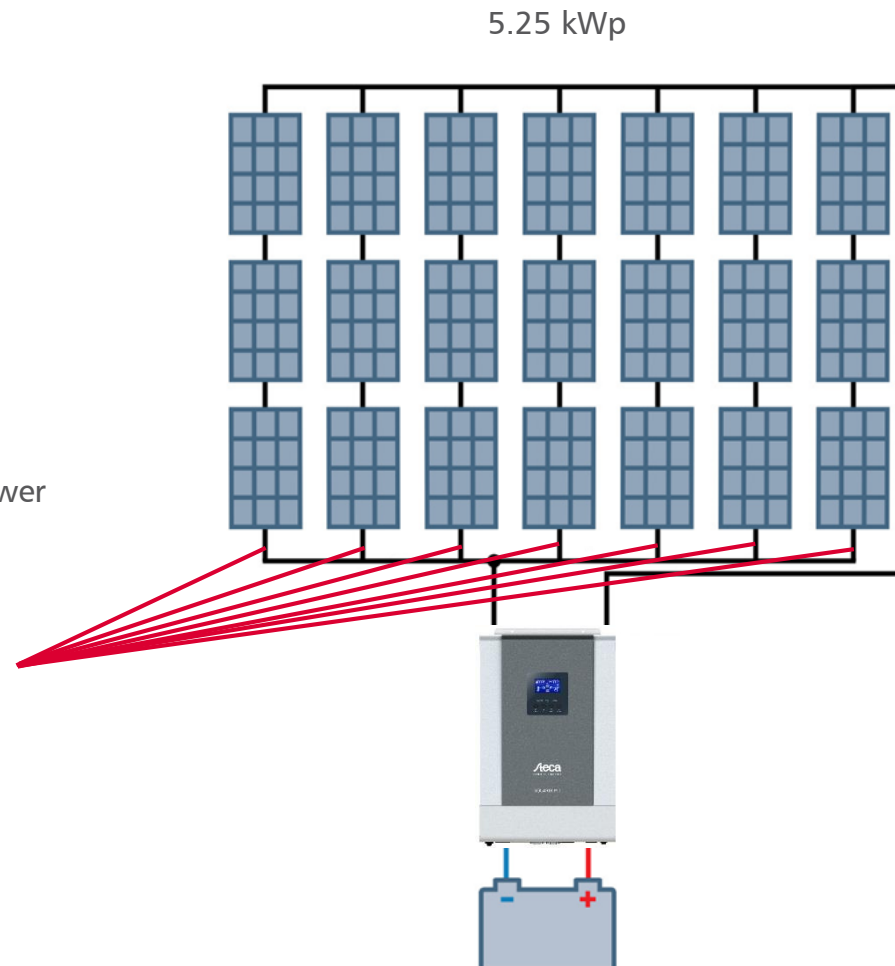

# INVERTER SYSTEMS

## SOLARIX PLI 2400-24

### PV sizing example for Solarix PLI 2400-24

- PV module specifications:
  - 250 Wp modules (60 cells)
  - $U_{mpp} = 31.2V$
  - $U_{oc} = 37.6V$
  - $I_{sc} = 8.5A$
- Battery voltage 24 V, maximum usable power 1168 W
- String fuses are likely required when using more than 2 strings in parallel

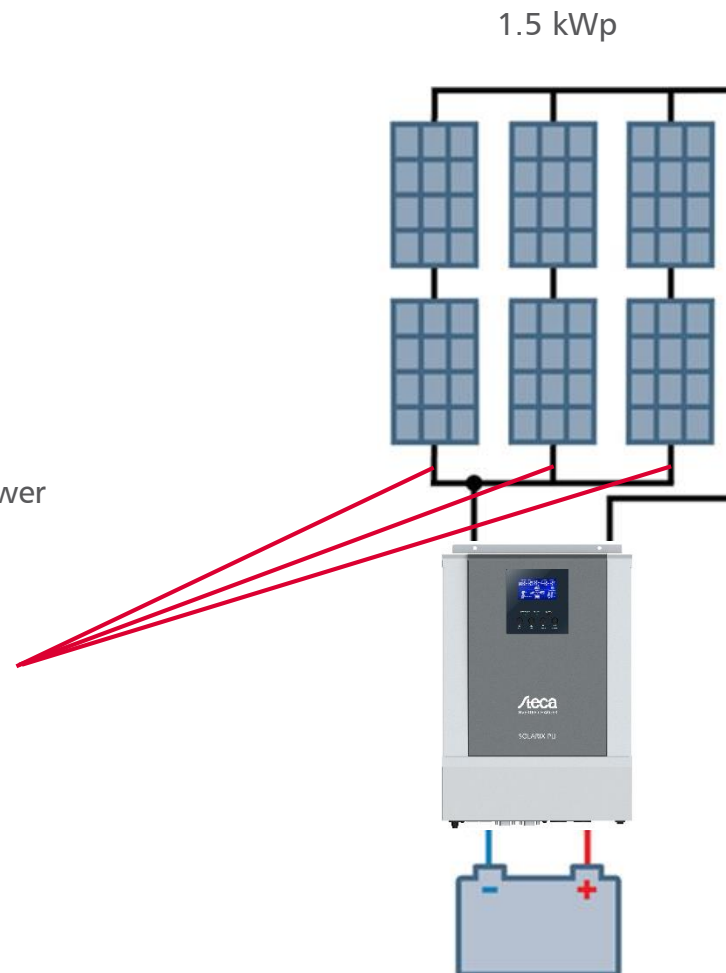

# INVERTER SYSTEMS

## SOLARIX PLI 1000-12

### PV sizing example for Solarix PLI 1200-12

- PV module specifications:
  - 250 Wp modules (60 cells)
  - $U_{mpp} = 31.2V$
  - $U_{oc} = 37.6V$
  - $I_{sc} = 8.5A$
- Battery voltage 12 V, maximum usable power 550 W
- Alternatively to the diagram on the right, two such PV modules could be wired in parallel, instead of in series.

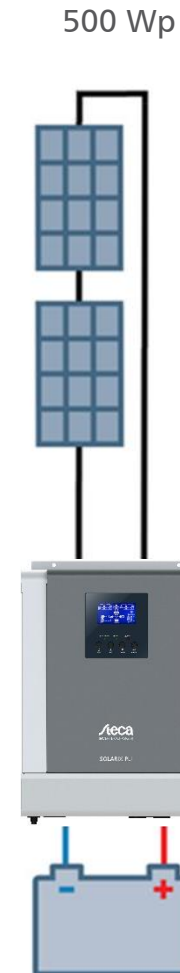

### Further considerations

- Ensure a sufficient battery capacity, especially when using an inverter on the same battery.  
Minimum battery size:

- $(\text{Nominal AC Power} * 5h) / \text{Battery voltage} = \text{Min. capacity in Ah}$

Feature: the Solarix has an integrated soft-start function so no high currents will flow when first connecting it to a battery.

- Use of a surge protector (SPD) at the PV input (if used) is strongly recommended!

Example: Citel DS240S-110DC for Solarix PLI 5000-48

- The clamping voltage must be lower than 160 Vdc
  - The maximum DC operating voltage must be higher than the maximum open-circuit voltage of your PV modules under all temperature conditions

Example: Citel DS240S-75DC for Solarix PLI 2400-24 and Solarix PLI 1000-12

- The clamping voltage must be lower than 110 Vdc
  - The maximum DC operating voltage must be higher than the maximum open-circuit voltage of your PV modules under all temperature conditions

- Use of a surge protector (SPD) at the AC input (if used) is strongly recommended! The clamping voltage must be lower than 300 Vac.
- As with any electronics: keep as cool as possible

# Steca

## CONTACT DATA



### Steca Elektronik GmbH

Mammostraße 1  
87700 Memmingen  
Deutschland

Tel. +49-(0)8331-8558-0  
Fax +49-(0)8331-8558-131

E-Mail: [info@steca.de](mailto:info@steca.de)

[www.steca.de](http://www.steca.de)



[facebook.com/StecaElektronik](https://facebook.com/StecaElektronik)



[youtube.com/c/StecaElektronik](https://youtube.com/c/StecaElektronik)