



GOODWE
YOUR SOLAR ENGINE

Power Whenever You Need

Residential & Small Commercial
Energy Storage Solutions

1. Hybrid Solutions

- ✓ On-grid & backup function integrated
- ✓ Especially designed for newly installed systems

1.1 Typical Application

- Enhance self-consumption: During the day, the electricity from the PV array is used to optimize self-consumption. The excess power charges the the batteries, whose power supplies the loads at night. By utilizing storage, the self-consumption can reach up to 95%.
- Benefit from peak shaving: By setting the charging and discharging time, the battery can be charged using the electricity generated at off-peak rates and discharged to fulfill the loads during peak hours (if the grid regulations allow it).
- Provide backup for critical loads: Connected to the backup side of the inverter, loads such as refrigerators, routers, lamps, computers and other critical appliances can be powered when the grid fails. The system can automatically switch to backup mode within 10 milliseconds.

System Wiring and Operation

■ AC cable ■ DC cable ■ COM cable

The hybrid inverters are the core of the energy storage systems and they are integrated following elements into one unit: MPP trackers, power inverter, battery charging & discharging function, BMS communication & by-pass & backup function. GoodWe's hybrid portfolio is a perfect fit for a great number of residential and small commercial scenarios.

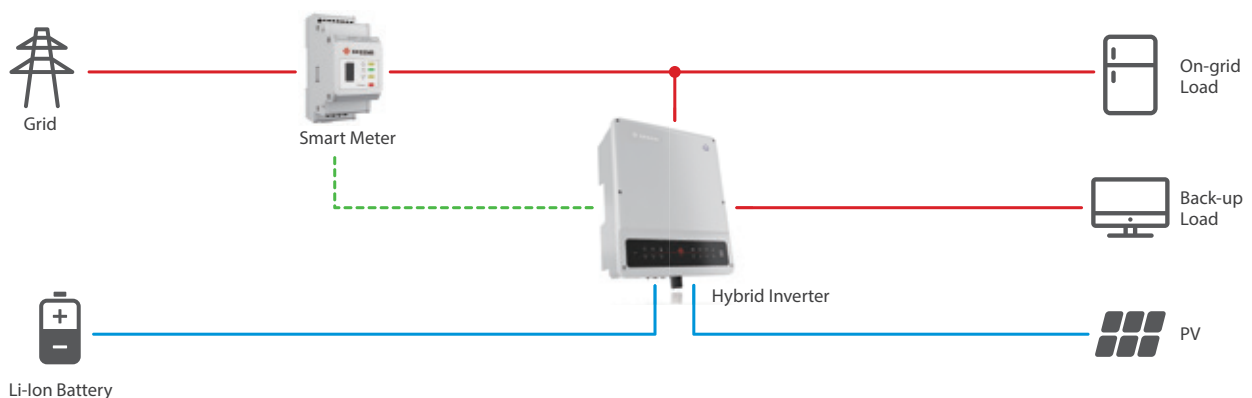

Operation Modes

There are three basic modes that end users can choose from the PV Master App.

- General Mode: At daytime, the power generated by the PV system is used in the following order: First, feed the home loads; second, charge the battery and third, export the surplus power to the grid. At night, the battery powers the loads. If the power supply from the batteries is not sufficient, the system is designed to switch automatically to the grid in order to keep the loads supplied.
- Backup Mode: Under this mode, the battery is only used as a backup power supply when the grid fails and as long as the grid works, the batteries won't be used to power the loads. The battery will get charged with the power generated by the PV system or from the grid.
- Economic Mode: The customer is able to set the battery charging and discharging times according to the grid peak and off-peak tariffs and the household power consumption habits.

1.2 All in One System (ESA Series)

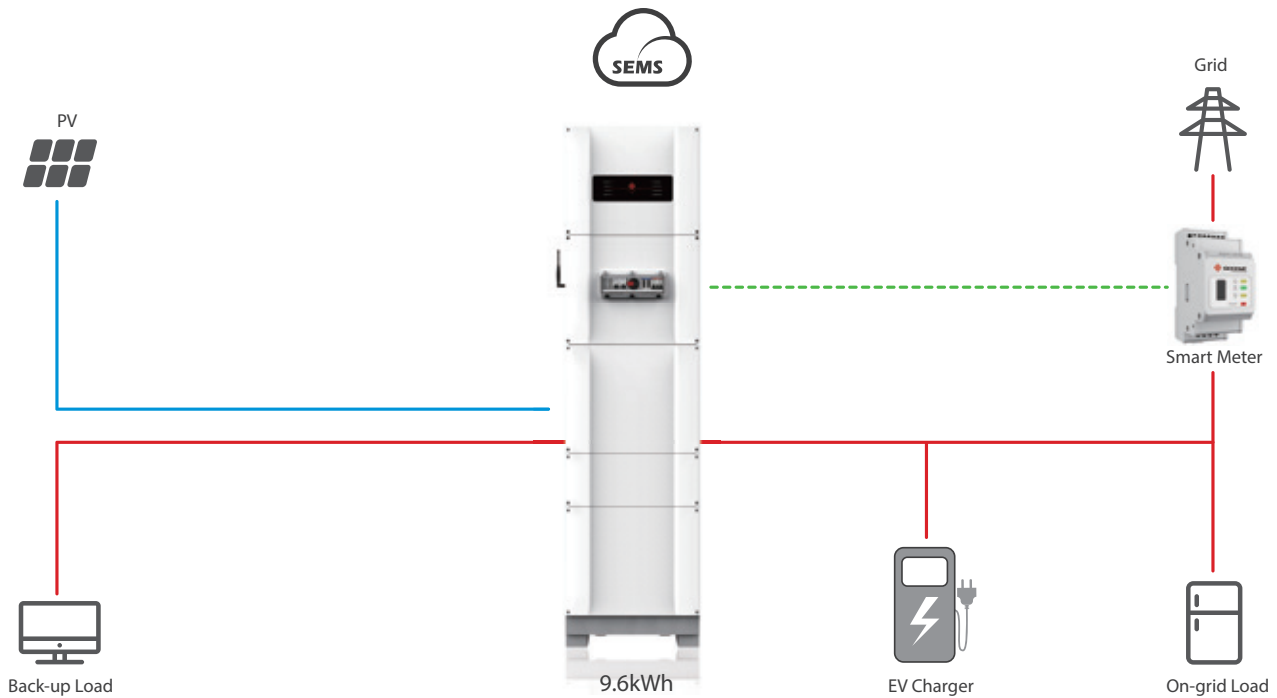

GoodWe is pleased to introduce the ESA Series, an “All-in-One” hybrid system that is designed to simplify the installation process to the maximum. It consists of the following elements: a hybrid inverter, a battery bank and a pre-wired system located inside a modern cabinet; it also includes connection devices and a preset cable slot. It is estimated that this system reduces the installation cost by as much as 60%!

Features

- Pre-Installed Devices: Built-in DC switch, AC breaker (On-Grid/Backup), battery breaker, switch board, earth terminal and communication unit.
- Pre-Wired Design: The smart meter, the battery and the AC breaker are pre-wired and pre-connected at the factory and at the moment the set reaches the end users, it is ready to be deployed and installed.
- Preset Cable Slot: As part of the systems design, there is a cable slot, where external PV and CT cables to the grid or the loads can be placed.
- In addition, the ESA system is also equipped with an AC load bypass switch, used for switching the load supply from the backup to the grid; the bypass switch also performs the rapid shutdown protection through the connection of an additional external breaker with a switch board.

GoodWe Hybrid Portfolio

	ES	EM	ESA	EH	ET
Power Range	3.6-5kW	3-5kW	5kW+9.6kWh	3.6-6kW	5-10kW
Grid Type	Single-phase	Single-phase	Single-phase (All-in-One)	Single-phase	Three-phase
Lithium Battery	Low Voltage	Low Voltage	Low Voltage	High Voltage	High Voltage

2. AC coupled retrofit solution

- ✓ On-grid & backup function integrated
- ✓ Converting on-grid systems into hybrid systems

2.1 Typical Application

- Enhancing Self-Consumption: At daytime, the electricity from the PV array is used for self-consumption. The surplus is used to charge the batteries, which in turn can power the loads at night. The utilization of energy storage technologies can bring the self-consumption rate up to 95%.
- Provide Backup to Critical Loads: When the grid fails, the backup function of the hybrid inverter can feed power to critical loads such as refrigerators, routers, lamps, computers and other key appliances. The system automatically switches to backup mode within 10 milliseconds.

System Wiring and Operation

The GoodWe AC-coupled retrofit inverters are formed by the following key elements into one single unified unit: power inverter, the battery charging & discharging function, the BMS communication and the by-pass & backup function. This kind of inverter is designed to make it easy to convert and upgrade existing grid-tied systems into hybrid ones. It is suitable for both single-phase and three-phase systems, and it is also compatible with various power sources including solar and wind generators of different brands in both residential and commercial scenarios.

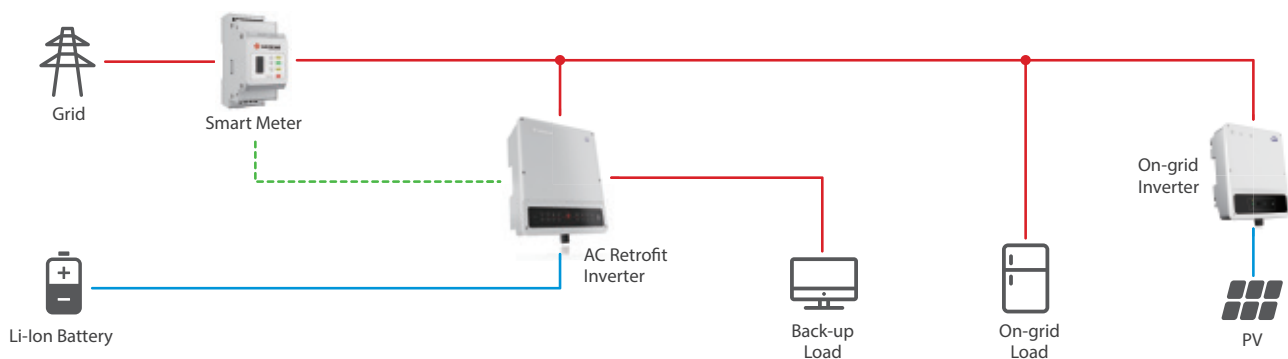

Operation Modes

In a similar way to the hybrid system, the default setting in the AC coupled retrofit inverter prioritizes the PV generation to power the loads, then charge the battery and finally export any surplus power to the grid. There are also three basic operation modes available in the PV Master App.

One major difference to a newly installed hybrid system is that PV will not work during the day time if there is an outage. This is because the original grid-tied inverter does not work when the grid fails and it is only the battery that powers the critical loads during the time that the outage lasts.

GoodWe Retrofit Family

	SBP	BH	BT
Power Range	3.6-5kW	1-6kW	5-10kW
Grid Type	Single-phase	Single-phase	Three-phase
Lithium Battery	Low Voltage	High Voltage	High Voltage

3. Extended Operation Scenarios

Based on their key functions and capabilities, the GoodWe energy storage inverters can be displayed on multiple scenarios. Below are some of the most frequent.

3.1 Paralleling Scenario (Only ET Series)

The new three-phase ET inverters paralleling solution is particularly designed to meet the increasing demand for PV storage systems with higher capacity, which is completely suitable for installation such as small commercial storage systems. This kind of solution involves the integration on the AC side of multiple hybrid inverters (maximum 10 units) into one unified system.

System Wiring and Operation

The use of the SEC1000 (GoodWe's Smart Energy Controller) is recommended to achieve a smooth interconnection of all the units when working under a paralleling scenario.

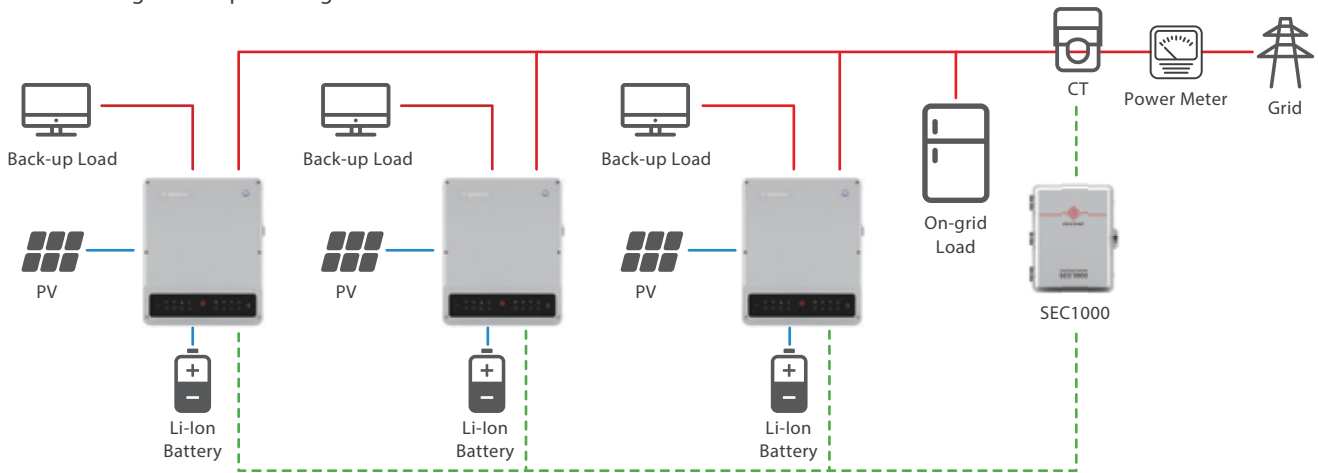

Operation Modes

It follows the same principal of the inverter paralleling scenario: when the grid is available, the PV system, the batteries and the loads share the energy in a united system. In contrast, when outage occurs, the paralleled system breaks into independent units in which the PV and the batteries supply backup power only to the corresponding loads.

3.2 Split-phase System Solution

A split-phase system, which differentiates from most European standards systems, has completely different application scenario. For such a grid, GoodWe provides a solution of a smart meter with two CTs to integrate both 110V and 220V loads on the grid side (see below).

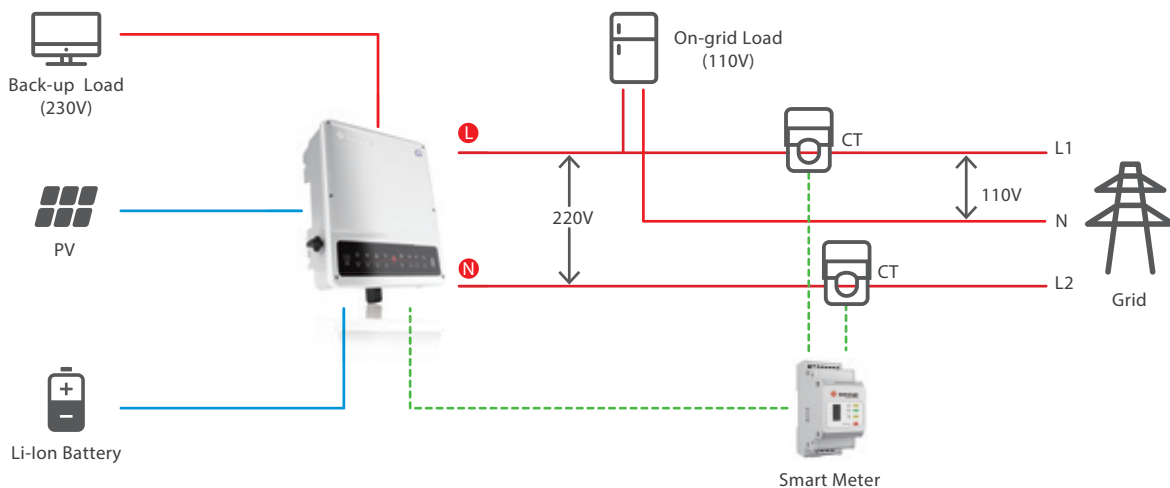

GoodWe energy storage ES, EM, and EH series are applicable.

3.3 Solution for Generator Connection

To develop this solution, GoodWe adopts the “Generator + Solar” concept. It is a response to situations in which the power generated by the solar system may be insufficient to provide backup support to the loads, for which case a generator is connected in parallel with the backup side through an ATS (Auto Transfer Switch) to provide emergency support to the backup loads.

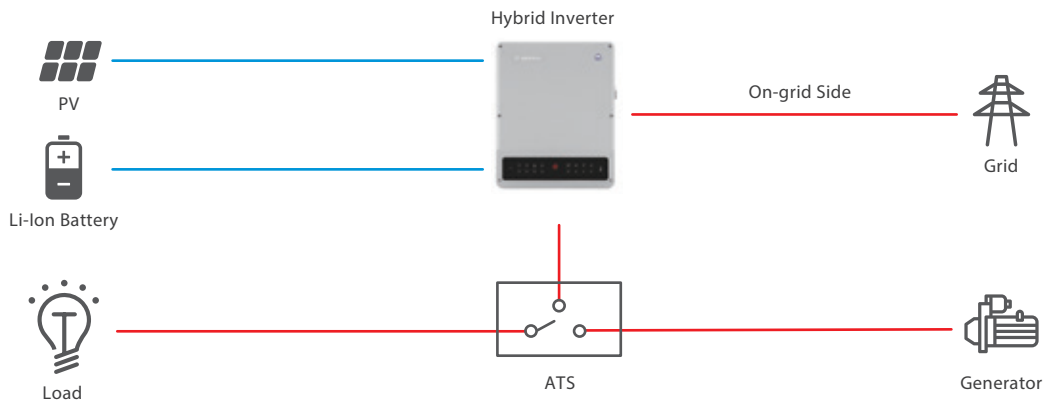

GoodWe energy storage ES, EM, EH and ET series are applicable.

The system is designed in a way that the solar system and the batteries prioritize the supply of energy to the backup loads. The system can also be manually adjusted to switch to the generator in order to supply the backup loads. When the solar system recovers its supply ability, the ATS resets the system so that the loads are supplied again by the solar system.

3.4 Solution to achieve solar capacity extension

The extension of solar capacity is a characteristic that makes solar energy storage systems very attractive because they help reduce the required investment, also allowing adaptation to higher power consumption patterns in both single and three phase systems.

This kind of solution is suitable for the GoodWe ES, EM, EH and ET Series. It can also work with any brand of solar inverters.

System Wiring and Operation

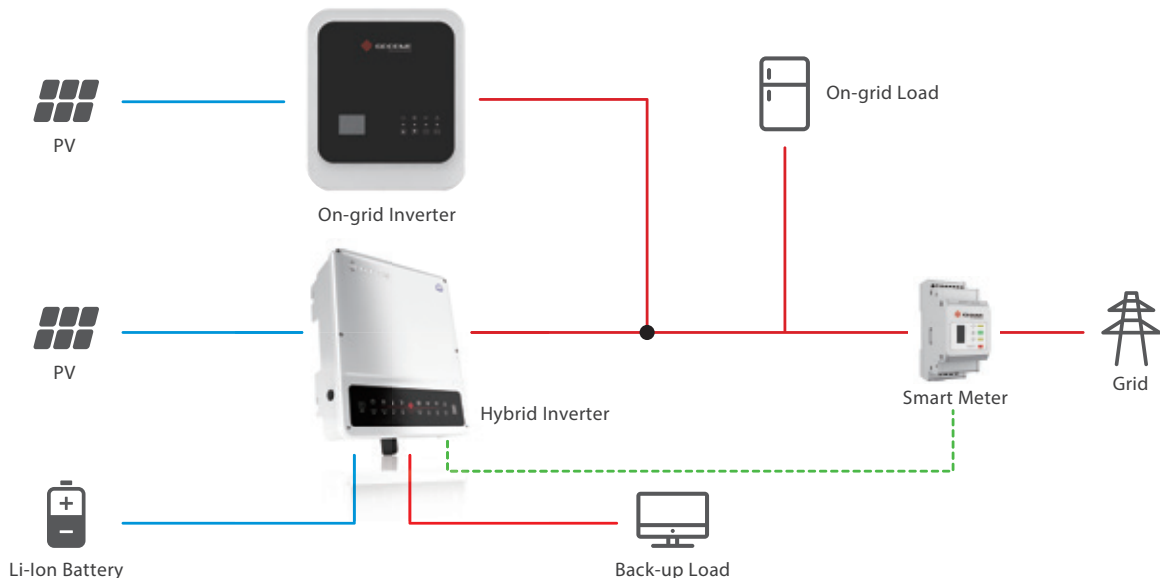

This solution integrates both hybrid and retrofit functions into a single system. In both on-grid systems as well as hybrids, the solar energy is used to supply electricity to both back-up loads and to charge the battery before the power is injected into the grid. By adopting such a solution, the system provides a more reliable source of supply for the loads, while ensuring a sufficient supply of green energy to charge the battery.

EH Series

Single Phase Hybrid Inverter (HV Battery)



Technical Data		GW3600-EH	GW5000-EH	GW6000-EH
Battery Input Data	Battery Type	Li-Ion		
	Battery Voltage Range(V)	85~450		
	Start-up Voltage (V)	90		
	Max. Charging/Discharging Current (A)	25/25		
	Max. Charging/Discharging Power (W)	3600	5000	6000
	Battery Ready Optional Function	YES	YES	YES
PV String Input Data	Max. DC Input Power (W)	4800	6650	8000
	Max. DC Input Voltage (V)	580		
	MPPT Range (V)	100~550		
	Start-up Voltage (V)	90		
	Nominal DC Input Voltage (V)	380		
	Max. Input Current (A)	12.5/12.5		
	Max. Short Current (A)	15.2/15.2		
	No. of MPP Trackers	2		
No. of Strings per MPP Tracker	1			
AC Output/Input Data (On-grid)	Nominal Apparent Power Output to Utility Grid (VA) ^{*2}	3600	5000	6000
	Max. Apparent Power Output to Utility Grid(VA) ^{*2}	3600/3960 ^{*1}	5000/5500 ^{*1}	6000/6600 ^{*1}
	Max. Apparent Power from Utility Grid (VA)	7200 (Charging 3.6kw,back-up output3.6kw)	10000 (Charging 5kw,back-up output 5kw)	12000 (Charging 6kw,back-up output 6kw)
	Nominal Output Voltage (V)	230		
	Nominal Output Frequency (Hz)	50/60		
	Max. AC Current Output to Utility Grid (A) ^{*2}	16/18 ^{*1}	21.7/24 ^{*1}	26.1/28.7 ^{*1}
	Max. AC Current From Utility Grid (A)	32	43.4	52.2
	Output Power Factor	~1 (Adjustable from 0.8 leading to 0.8 lagging)		
	Output THDi (@Nominal Output)	<3%		
	Back-up Output Data (Back-up)	Max. Output Apparent Power (VA)	3600	5000
Peak Output Apparent Power (VA)		4320 ,60sec	6000 ,60sec	7200 ,60sec
Max. Output Current (A)		15.7	21.7	26.1
Nominal Output Voltage (V)		230 (±2%)		
Automatic Switch Time (ms)		<10		
Nominal Output Frequency (Hz)		50/60 (±0.2%)		
Output THDv (@Linear Load)		<3%		
Efficiency	PV Max. Efficiency	97.6%		
	PV Europe Efficiency	97.0%		
	PV Max. MPPT Efficiency	99.9%		
	Battery Charged by PV Max. Efficiency	98.0%		
	Battery Charge/Discharge from/to AC Max. Efficiency	96.6%		
Protection	Anti-Islanding Protection	Integrated		
	Battery Input Reverse Polarity Protection	Integrated		
	Insulation Resistor Detection	Integrated		
	Residual Current Monitoring Unit	Integrated		
	Output Over Current Protection	Integrated		
	Grid Output Short Protection	Integrated		
	Output Over Voltage Protection	Integrated		
General Data	Operating Temperature Range (°C)	-35~60		
	Relative Humidity	0~95%		
	Operating Altitude (m)	4000		
	Cooling	Natural Convection		
	Noise (dB)	<35		
	User Interface	LED & APP		
	Communication with BMS	CAN		
	Communication with Meter	RS485		
	Communication with Portal	Wi-Fi/Ethernet(Optional)		
	Weight (kg)	17		
	Size (Width*Height*Depth mm)	354*433*147		
	Mounting	Wall Bracket		
	Protection Degree	IP65		
	Standby Self-Consumption (W) ^{*3}	<10		
Topology	Transformerless			
Certifications & Standards	Grid Regulation	AS/NZS 4777.2:2015; G98/1; CEI 0-21 VDE4105-AR-N	AS/NZS 4777.2:2015; G99/1; CEI 0-21; VDE4105-AR-N	
	Safety Regulation	IEC/EN62109-1&-2		
	EMC	EN61000-6-1,EN61000-6-2,EN61000-6-3,EN61000-6-4,EN61000-4-16, EN 61000-4-18, EN 61000-4-29		

^{*1} For CEI 0-21.

^{*2} The grid feed in power for VDE-AR-N 4105 and NRS097-2-1 is limited 4600VA, for AS/NZS 4777.2 is limited 4950VA & 21.7A.

^{*3} No back-up output.

ET Series

Three Phase Hybrid Inverter (HV Battery)



Technical Data		GW5K-ET	GW8K-ET	GW10K-ET
Battery Input Data	Battery Type	Li-Ion		
	Battery Voltage Range (V)	180~600		
	Max. Charging Current (A)	25		
	Max. Discharging Current (A)	25		
	Charging Strategy for Li-Ion Battery	Self-adaption to BMS		
PV String Input Data	Max. DC Input Power (W)	6500	9600	13000
	Max. DC Input Voltage (V)*1	1000		
	MPPT Range (V)*2	200~850		
	Start-up Voltage (V)	180		
	MPPT Range for Full Load (V)*3	240~850	380~850	460~850
	Nominal DC Input Voltage (V)*4	620		
	Max. Input Current (A)	12.5/12.5		
	Max. Short Current (A)	15.2/15.2		
	No. of MPP Trackers	2		
	No. of Strings per MPP Tracker	1/1		
	AC Output Data (On-grid)	Nominal Apparent Power Output to Utility Grid (VA)	5000	8000
Max. Apparent Power Output to Utility Grid (VA)*5		5500	8800	11000
Max. Apparent Power from Utility Grid (VA)		10000	15000	15000
Nominal Output Voltage (V)		400/380, 3L/N/PE		
Nominal Output Frequency (Hz)		50/60		
Max. AC Current Output to Utility Grid (A)		8.5	13.5	16.5
Max. AC Current from Utility Grid (A)		15.2	22.7	22.7
Output Power Factor		~1 (Adjustable from 0.8 leading to 0.8 lagging)		
Output THDi (@Nominal Output)		<3%		
AC Output Data (Back-up; Optional)		Max. Output Apparent Power (VA)	5000	8000
	Peak Output Apparent Power (VA)*6	10000, 60sec	16000, 60sec	16500, 60sec
	Max. Output Current (A)	8.5	13.5	16.5
	Nominal Output Voltage (V)	400/380		
	Nominal Output Frequency (Hz)	50/60		
	Output THDv (@Linear Load)	<3%		
Efficiency	Max. Efficiency	98.0%	98.2%	98.2%
	Max. Battery to Load Efficiency	97.5%		
	European Efficiency	97.2%	97.5%	97.5%
Protection	Anti-Islanding Protection	Integrated		
	PV String Input Reverse Polarity Protection	Integrated		
	Insulation Resistor Detection	Integrated		
	Residual Current Monitoring Unit	Integrated		
	Output Over Current Protection	Integrated		
	Output Short Protection	Integrated		
	Battery Input Reverse Polarity Protection	Integrated		
	Output Over Voltage Protection	Integrated		
General Data	Operating Temperature Range (°C)	-35~60		
	Relative Humidity	0~95%		
	Operating Altitude (m)	≤4000		
	Cooling	Nature Convection		
	Noise (dB)	<30		
	User Interface	LED & APP		
	Communication with BMS	RS485; CAN		
	Communication with Meter	RS485		
	Communication with EMS	RS485 (Insulated)		
	Communication with Portal	Wi-Fi		
	Weight (kg)	24		
	Size (Width*Height*Depth mm)	516*415*180		
	Mounting	Wall Bracket		
	Protection Degree	IP65		
	Standby Self-Consumption (W)*7	<15		
Topology	Transformerless			
Standards	Grid Regulation	CEI 0-21; VDE4105-AR-N; VDE0126-1-1; EN50438; G83/2; G100		
	Safety Regulation	IEC62109-1&-2, IEC62040-1		
	EMC	EN61000-6-1, EN61000-6-2, EN61000-6-3, EN61000-6-4, EN61000-4-16, EN61000-4-18, EN61000-4-29		

*1: For 1000V system, Maximum operating voltage is 950V. For AustraliaL safety, there will be a warning if PV voltage > 600V.

*2: For AustraliaL safety, MPPT range is 200~550V.

*3: For AustraliaL safety, MPPT voltage upper limit is 550V.

*4: For AustraliaL safety, nominal DC input voltage is 450V.

*5: According to the local grid regulation.

*6: Can be reached only if PV and battery power is enough.

*7: No Back-up Output.

ES Series

Single Phase Hybrid Inverter (LV Battery)



Technical Data		GW3648D-ES	GW5048D-ES
Battery Input Data	Battery Type	Li-Ion	
	Nominal Battery Voltage (V)	48	
	Max. Charging Voltage (V)	≤60 (Configurable)	
	Max. Charging Current (A)	75	100
	Max. Discharging Current (A)	75	100
	Battery Capacity (Ah)*1	50~2000	
Charging Strategy for Li-Ion Battery		Self-adaption to BMS	
PV String Input Data	Max. DC Input Power (W)*2	4600	6500
	Max. DC Input Voltage (V)	580	
	MPPT Range (V)	125~550	
	Start-up Voltage (V)*3	150	
	Nominal DC Input Voltage (V)	360	
	Max. Input Current (A)	11/11	
	Max. Short Current (A)	13.8/13.8	
	No. of MPP Trackers	2	
	No. of Strings per MPP Tracker	1	
	AC Output Data (On-grid)	Nominal Apparent Power Output to Utility Grid (VA)	3680
Max. Apparent Power Output to Utility Grid (VA)*4		3680	5100
Max. Apparent Power from Utility Grid (VA)		7360	9200
Nominal Output Voltage (V)		230	
Nominal Output Frequency (Hz)		50/60	
Max. AC Current Output to Utility Grid (A)		16	24.5*5
Max. AC Current from Utility Grid (A)		32	40
Output Power Factor		~1 (Adjustable from 0.8 leading to 0.8 lagging)	
AC Output Data (Back-up)	Output THDi (@Nominal Output)	<3%	
	Max. Output Apparent Power (VA)	3680	4600
	Peak Output Apparent Power (VA)*6	5520,10sec	6900,10sec
	Max. Output Current (A)	16	20
	Nominal Output Voltage (V)	230 (±2%)	
	Nominal Output Frequency (Hz)	50/60 (±0.2%)	
Efficiency	Output THDv (@Linear Load)	<3%	
	Max. Efficiency	97.6%	
	Max. Battery to Load Efficiency	94.0%	
Protection	European Efficiency	97.0%	
	Anti-Islanding Protection	Integrated	
	PV String Input Reverse Polarity Protection	Integrated	
	Insulation Resistor Detection	Integrated	
	Residual Current Monitoring Unit	Integrated	
	Output Over Current Protection	Integrated	
	Output Short Protection	Integrated	
General Data	Output Over Voltage Protection	Integrated	
	Operating Temperature Range (°C)	-25~60	
	Relative Humidity	0~95%	
	Operating Altitude (m)	≤4000	
	Cooling	Natural Convection	
	Noise (dB)	<25	
	User Interface	LED & APP	
	Communication with BMS*7	RS485; CAN	
	Communication with Meter	RS485	
	Communication with Portal	Wi-Fi	
	Weight (kg)	28	30
	Size (Width*Height*Depth mm)	516*440*184	
	Mounting	Wall Bracket	
Protection Degree	IP65		
Standby Self-Consumption (W)	<13		
Topology	High Frequency Isolation		
Certifications & Standards	Grid Regulation	VDE-AR-N 4105, VDE0126-1-1, AS4777.2, G83/2, CEI 0-21, NRS 097-2-1, EN50438	VDE-AR-N 4105, VDE0126-1-1, AS4777.2, G59/3, CEI 0-21, NRS 097-2-1, EN50438
	Safety Regulation	IEC/EN62109-1&-2, IEC62040-1	
	EMC	EN61000-6-1, EN61000-6-2, EN61000-6-3, EN61000-6-4, EN61000-4-16, EN61000-4-18, EN 61000-4-29	

*1: Under off-grid mode, then battery capacity should be more than 100Ah.

*2: For South Africa, Max. DC Input ranges from 6kW to 6.5kW.

*3: When there is no battery connected, inverter starts feeding in only if string voltage is higher than 200V.

*4: 4600W for VDE 0126-1-1 & VDE-AR-N4105, 4950W for AS4777.2(GW5048D-ES); 4050W for CEI 0-21 (GW3648D-ES).

*5: 21.7A for AS4777.2.

*6: Can be reached only if PV and battery power are enough.

*7: The standard configuration is CAN.

EM Series

Single Phase Hybrid Inverter (LV Battery)



Technical Data		GW3048-EM	GW3648-EM	GW5048-EM
Battery Input Data	Battery Type	Li-Ion		
	Nominal Battery Voltage (V)	48		
	Max. Charging Voltage (V)	≤60 (Configurable)		
	Max. Charging Current (A)	50		
	Max. Discharging Current (A)	50		
	Battery Capacity (Ah)* ¹	50~2000		
Charging Strategy for Li-Ion Battery		Self-adaption to BMS		
PV String Input Data	Max. DC Input Power (W)	3900	4600	6500
	Max. DC Input Voltage (V)* ²	550		
	MPPT Range (V)	100~500		
	Start-up Voltage (V)* ³	150		
	Nominal DC Input Voltage (V)	360		
	Max. Input Current (A)	11	11/11	11/11
	Max. Short Current (A)	13.8	13.8/13.8	13.8/13.8
	No. of MPP Trackers	1	2	2
	No. of Strings per MPP Tracker	1		
AC Output Data (On-grid)	Nominal Apparent Power Output to Utility Grid (VA)	3000	3680	5000* ⁴
	Max. Apparent Power Output to Utility Grid (VA)* ⁵	3000	3680	5000
	Max. Apparent Power from Utility Grid (VA)	5300		
	Nominal Output Voltage (V)	230		
	Nominal Output Frequency (Hz)	50/60		
	Max. AC Current Output to Utility Grid (A)	13.6	16	22.8* ⁶
	Max. AC Current From Utility Grid (A)	23.6		
	Output Power Factor	~1 (Adjustable from 0.8 leading to 0.8 lagging)		
	Output THDi (@Nominal Output)	<3%		
AC Output Data (Back-up)	Max. Output Apparent Power (VA)	2300		
	Peak Output Apparent Power (VA)* ⁷	3500,10sec		
	Automatic Switch Time (ms)	10		
	Max. Output Current (A)	10		
	Nominal Output Voltage (V)	230 (±2%)		
	Nominal Output Frequency (Hz)	50/60 (±0.2%)		
Efficiency	Output THDv (@Linear Load)	<3%		
	Max. Efficiency	97.6%		
	Max. Battery to Load Efficiency	94.5%		
Protection	European Efficiency	97.0%		
	Anti-Islanding Protection	Integrated		
	PV String Input Reverse Polarity Protection	Integrated		
	Insulation Resistor Detection	Integrated		
	Residual Current Monitoring Unit	Integrated		
	Output Over Current Protection	Integrated		
	Output Short Protection	Integrated		
General Data	Output Over Voltage Protection	Integrated		
	Operating Temperature Range (°C)	-25~60		
	Relative Humidity	0~95%		
	Operating Altitude (m)	4000		
	Cooling	Natural Convection		
	Noise (dB)	<25		
	User Interface	LED & APP		
	Communication with BMS* ⁸	RS485; CAN		
	Communication with Meter	RS485		
	Communication with Portal	Wi-Fi		
	Weight (kg)	16	17	17
	Size (Width*Height*Depth mm)	347*432*175		
	Mounting	Wall Bracket		
	Protection Degree	IP65		
Standby Self-Consumption (W)	<13			
Certifications & Standards	Topology	High Frequency Isolation		
	Grid Regulation	AS/NZS 4777.2:2015, G83/2, G100, CEI 0-21, VDE4105-AR-N, VDE0126-1-1, NRS 097-2-1, RD1699, UNE206006, EN50438		
	Safety Regulation	IEC/EN62109-1&-2, IEC62040-1		
	EMC	EN61000-6-1, EN61000-6-2, EN61000-6-3, EN61000-6-4, EN 61000-4-16, EN 61000-4-18, EN 61000-4-29		

*¹: Under off-grid mode, then battery capacity should be more than 100Ah.

*²: Maximum operating DC voltage is 530V.

*³: When there is no battery connected, inverter starts feeding in only if string voltage is higher than 200V.

*⁴: 4600 for VDE0126-1-1&VDE-AR-N4105 & CEI 0-21(GW5048-EM).

*⁵: For CEI 0-21 GW3048-EM is 3300W, GW3648-EM is 4050W, GW5048-EM is 5100W; for VDE-AR-N4105 GW5048-EM is 4600.

*⁶: 21.7A for AS4777.2.

*⁷: Can be reached only if PV and battery power are enough.

*⁸: The standard configuration is CAN.

BH Series (AC-Coupled)

Single Phase AC Retrofit Inverter (HV Battery)



Technical Data		GW1000-BH	GW2000-BH	GW3000-BH	GW3K-BH	GW3600-BH	GW5000-BH	GW6000-BH	
Battery Input Data	Battery Type	Li-Ion			Li-Ion				
	Battery Voltage Range (V)	80~400			85~400	85~450			
	Start-up Voltage (V)	80			90				
	Max. Charging/Discharging Current (A)	13	15	15	32/32	25/25			
AC Output Data /Input Data (On-grid)	Nominal Power Output to Utility Grid (W)	1000	2000	3000	3000	3600	4600/5000* ¹	4600/5000/6000* ²	
	Max. Apparent Power Output to Utility Grid (VA)	1000	2000	3000	3000	3600/3960* ³	4600/5000/5500* ⁴	4600/5000/6000/6600* ⁵	
	Max. Apparent Power from Utility Grid (VA)	1000	2000	3000	6000(Charging 3kw, back-up output 3kw)	7200(Charging 3.6kw, back-up output 3.6kw)	10000(Charging 5kw, back-up output 5kw)	12000(Charging 6kw, back-up output 6kw)	
	Nominal Output Voltage (V)	230			230				
	Nominal Output Frequency (Hz)	50/60			50/60				
	Max. AC Current Output to Utility Grid (A)	5	10	13.5	13.1	16/18* ⁶	21.7/24* ⁷	21.7* ⁸ /26.1/28.7* ⁹	
	Max. AC Current from Utility Grid (A)	NA			27	32	43.4	52.2	
	Output Power Factor	~1 (Adjustable from 0.8 leading to 0.8 lagging)				~1 (Adjustable from 0.8 leading to 0.8 lagging)			
	Output THDi (@Nominal Output)	<3%			<3%				
	Output Data (Back-up)	Max. Output Apparent Power (VA)	No Back-up			3000	3600	5000	6000
Peak Output Apparent Power (VA)		3600, 60SEC				4320, 60SEC	6000, 60SEC	7200, 60SEC	
Max. Output Current (A)		13.1				16	21.7	26.1	
Automatic Switch Time (ms)		<10							
Nominal Output Voltage (V)		230 (±2%)							
Nominal Output Frequency (Hz)		50/60 (±0.2%)							
Output THDv (@Linear Load)		<3%							
Efficiency	Max. Efficiency	96.0%	96.5%	96.5%	96.6%				
Protection	Anti-Islanding Protection	Integrated			Integrated				
	Battery Input Reverse Polarity Protection	Integrated			Integrated				
	Insulation Resistor Detection	Integrated			Integrated				
	Residual Current Monitoring Unit	Integrated			Integrated				
	Output Over Current Protection	Integrated			Integrated				
	Output Short Protection	Integrated			Integrated				
	Output Over Voltage Protection	Integrated			Integrated				
General Data	Operating Temperature Range (°C)	-35~60			-35~60				
	Relative Humidity	0~95%			0~95%				
	Operating Altitude (m)	≤4000			4000				
	Cooling	Natural Convection			Natural Convection				
	Noise (dB)	<25			<35				
	User Interface	LED & APP			LED & APP				
	Communication with BMS	CAN			CAN				
	Communication with Meter	RS485			RS485				
	Communication with Portal	Wi-Fi/Ethernet (Optional)			Wi-Fi/Ethernet (Optional)				
	Weight (kg)	8.5			15.5				
	Size (Width*Height*Depth mm)	344*274.5*128			354*433*147				
	Mounting	Wall Bracket			Wall Bracket				
	Protection Degree	IP65			IP65				
	Standby Self-Consumption (W)* ¹⁰	<15			<10				
	Topology	Transformerless			Transformerless				
Certifications & Standards	Grid Regulation	G98			AS/NZS 4777.2:2015	AS/NZS 4777.2:2015; G99; CEI 0-21; VDE4105-AR-N			
	Safety Regulation	-			IEC/EN 62477-1, AS 62040.1.1				
	EMC	EN61000-6-1, EN61000-6-2, EN61000-6-3, EN61000-6-4, EN61000-4-16, EN61000-4-18, EN61000-4-29			EN61000-6-1, EN61000-6-2, EN61000-6-3, EN61000-6-4, EN61000-4-16, EN61000-4-18, EN61000-4-29				

*¹4600 for VDE-AR-N 4105, 4950 for AS/NZS 4777.2, 5000 for other country.

*²4600 for VDE-AR-N 4105, 4950 for AS/NZS 4777.2 feed in power limit.

*³3960 for CEI 0-21, 3600 for other countries.

*⁴4600 for VDE-AR-N 4105, 4950 for AS/NZS 4777.2, 5500 for CEI 0-21, 5000 for other country.

*⁵4600 for VDE-AR-N 4105, 4950 for AS/NZS 4777.2, 6600 for CEI 0-21, 6000 for other country.

*⁶ *⁷ *⁸ *⁹ for CEI 0-21.

*⁸ 21.7 for AS/NZS 4777.2 feed in power limit, selfuse can reach 26.1A.

*¹⁰ No back-up output.

BT Series (AC-Coupled)

Three Phase AC Retrofit Inverter (HV Battery)



Technical Data		GW5K-BT	GW6K-BT	GW8K-BT	GW10K-BT
Battery Input Data	Battery Type	Li-Ion			
	Battery Voltage Range (V)	180~600			
	Max. Charging Current (A)	25			
	Max. Discharging Current (A)	25			
	Charging Strategy for Li-Ion Battery	Self-adaption to BMS			
AC Output Data (On-grid)	Nominal Apparent Power Output to Utility Grid (VA)	5000	6000	8000	10000
	Max. Apparent Power Output to Utility Grid (VA) *1	5500	6600	8800	11000
	Max. Apparent Power from Utility Grid (VA)	10000	12000	15000	15000
	Nominal Output Voltage (V)	400/380, 3L/N/PE			
	Nominal Output Frequency (Hz)	50/60			
	Max. AC Current Output to Utility Grid (A)	8.5	10.5	13.5	16.5
	Max. AC Current from Utility Grid (A)	15.2	18.2	22.7	22.7
	Output Power Factor	~1 (Adjustable from 0.8 leading to 0.8 lagging)			
	Output THDi (@Nominal Output)	<3%			
AC Output Data (Back-up)	Max. Output Apparent Power (VA)	5000	6000	8000	10000
	Peak Output Apparent Power (VA) *2	10000, 60sec	12000, 60sec	15000, 60sec	15000, 60sec
	Max. Output Current (A)	8.5	10.5	13.5	16.5
	Nominal Output Voltage (V)	400/380			
	Nominal Output Frequency (Hz)	50/60			
	Output THDv (@Linear Load)	<3%			
Efficiency	Max. Battery to Load Efficiency	97.6%			
	Max. Charge Efficiency	97.6%			
Protection	Anti-Islanding Protection	Integrated			
	Insulation Resistor Detection	Integrated			
	Residual Current Monitoring Unit	Integrated			
	Output Over Current Protection	Integrated			
	Output Short Protection	Integrated			
	Battery Input Reverse Polarity Protection	Integrated			
	Output Over Voltage Protection	Integrated			
General Data	Operating Temperature Range (°C)	-35~60			
	Relative Humidity	0~95%			
	Operating Altitude (m)	≤4000			
	Cooling	Nature Convection			
	Noise (dB)	<30			
	User Interface	LED & APP			
	Communication with BMS	RS485; CAN *4			
	Communication with Meter	RS485			
	Communication with EMS	RS485 (Insulated)			
	Communication with Portal	Wi-Fi; LAN			
	Weight (kg)	21			
	Size (Width*Height*Depth mm)	516*415*180			
	Mounting	Wall Bracket			
	Protection Degree	IP65			
	Standby Self-Consumption (W) *3	<15			
	Topology	Transformerless			
Certifications & Standards	Grid Regulation	CEI 0-21; VDE-AR-N 4105; G98/1; G100			
	Safety Regulation	IEC62477			
	EMC	EN61000-6-1, EN61000-6-2, EN61000-6-3, EN61000-6-4, EN 61000-4-16, EN 61000-4-18, EN 61000-4-29			

*1: According to the local grid regulation.

*2: Can be reached only if battery capacity is enough, otherwise will shut down.

*3: No back-up output.

*4: CAN communication is configured by default. If 485 communication is used, please replace the corresponding communication line.

SBP Series (AC-Coupled)

Single Phase AC Retrofit Inverter (LV Battery)



Technical Data		GW3600S-BP	GW5000S-BP
Battery Input Data	Battery Type	Li-Ion	
	Nominal Battery Voltage (V)	48	
	Max. Charging Voltage (V)	≤60 (Configurable)	
	Max. Charging Current (A)	75	100
	Max. Discharging Current (A)	75	100
	Battery Capacity (Ah)*1	50~2000	
	Charging Strategy for Li-Ion Battery	Self-adaption to BMS	
AC Output Data (On-grid)	Nominal Power Output to Utility Grid (W)	3680	5000*2
	Max. Apparent Power Output to Utility Grid (VA) ³	3680	5000
	Max. Apparent Power from Utility Grid (VA)	7360	9200
	Nominal Output Voltage (V)	230	
	Nominal Output Frequency (Hz)	50/60	
	Max. AC Current Output to Utility Grid (A)	16	22.8*4
	Max. AC Current from Utility Grid (A)	32	40
	Output Power Factor	~1(Adjustable from 0.8 leading to 0.8 lagging)	
	Output THDi (@Nominal Output)	<3%	
AC Output Data (Back-up)	Max. Output Apparent Power (VA) ⁵	3680	5000
	Peak Output Apparent Power (VA) ⁵	4416, 10sec	5500, 10sec
	Automatic Switch Time (ms)	<10	
	Nominal Output Voltage (V)	230 (±2%)	
	Nominal Output Frequency (Hz)	50/60 (±0.2%)	
	Max. Output Current (A)	16	22.8
	Output THDv (@Linear Load)	<3%	
Efficiency	Max. Efficiency	95.5%	
Protection	Anti-Islanding Protection	Integrated	
	Output Over Current Protection	Integrated	
	Output Short Protection	Integrated	
	Output Over Voltage Protection	Integrated	
General Data	Operating Temperature Range (°C)	-25~60	
	Relative Humidity	0~95%	
	Operating Altitude (m)	4000	
	Cooling	Nature Convection	
	Noise (dB)	<25	
	User Interface	LED & APP	
	Communication with BMS*6	RS485; CAN	
	Communication with Meter	RS485	
	Communication with Portal	Wi-Fi	
	Weight (kg)	18.5	
	Size (Width*Height*Depth mm)	347*432*190	
	Mounting	Wall Bracket	
	Protection Degree	IP65	
	Standby Self-Consumption (W)	<15	
Topology	High Frequency Isolation		
Certifications & Standards	Grid Regulation	AS/NZS 4777.2:2015, G83/2, G100, CEI 0-21; RD1699; UNE206006; VDE4105-AR-N; VDE0126-1-1; EN50438	AS/NZS 4777.2:2015, G59/3, G100, CEI 0-21; RD1699; UNE206006; VDE4105-AR-N; VDE0126-1-1; EN50438
	Safety Regulation	IEC62477-1, IEC62040-1	
	EMC	EN 61000-6-1, EN 61000-6-2, EN 61000-6-3, EN 61000-6-4, EN 61000-4-16, EN 61000-4-18, EN 61000-4-29	

*1: Battery capacity could be not less than 100Ah where the back-up function is to be applied.

*2: 4600W for VDE0126-1-1&VDE-AR-N 4105 and CEI 0-21.

*3: For CEI 0-21 GW3600S-BP is 4050W, GW5000S-BP is 5100W; for VDE-AR-N4105 GW5000S-BP is 4600W.

*4: 21.7A for AS4777.2.

*5: Can be reached only if battery capacity is enough, otherwise will shut down.

*6: The standard configuration is CAN.

ESA Series

All-In-One Single Phase Storage Solution

Technical Data	GW5048-ESA
Battery Module Data	
Battery Type	Li-Ion
Battery Module Nominal Capacity(KWh)	2.4
Battery Module Weight(Kg)	24
Size (Width*Height*Depth mm)	440 x 410 x 88.5mm
Cycle Life(25°C)	>6000
Maximum Number of Battery Connections	4
Maximum Total Battery Capacity (KWh)	9.6
Battery Enclosure Data	
Weight (kg)	37
Size (Width*Height*Depth mm)	516 x 1205 x 280
Mounting	Wall Bracket
Protection Degree	IP54
Inverter Data	
Battery Input Data	
Nominal Battery Voltage (V)	48
Battery Voltage Range(V)	40~60
Maximum Charging Power (W)	4600
Maximum Discharging Power (W)	4600
Maximum Charging Current(A)	85
Maximum Discharging Current(A)	100
Battery Charging Method	Self-adaption to BMS
Battery Disconnect	Integrated 2 pole DC breaker 125A DC per pole
PV String Input Data	
Max. DC Input Power (W)	6500
Max. DC Input Voltage (V)	580
MPPT Range (V)	125~550
Start-up Voltage (V)	150
MPPT Range for Full Load (V)	215~500
Nominal DC Input Voltage (V)	360
Max. Input Current (A)	11/11
Max. Short Current (A)	13.8/13.8
No. of MPP Trackers	2
No. of Strings per MPP Tracker	1
Solar Array Switch	Integrated



Technical Data	GW5048-ESA	Technical Data	GW5048-ESA
AC Output Data (On-grid)		Insulation Resistor Detection	Integrated
Max. Apparent Power Output to Utility Grid (VA)*	4600/5100	Residual Current Monitoring Unit	Integrated
Max. Apparent Power from Utility Grid (VA)	9200	Output Over Current Protection	Integrated
Nominal Output Voltage (V)	230	Output Short Protection	Integrated
Nominal Output Frequency (Hz)	50/60	Output Over Voltage Protection	Integrated
Max. AC Current Output to Utility Grid (A)	22.8	General Data	
Max. AC Current From Utility Grid (A)	40	Operating Temperature Range (°C)	-25~60
Output Power Factor	~1 (Adjustable from 0.8 leading to 0.8 lagging)	Relative Humidity	0~95%
Output THDi (@Nominal Output)	<3%	Operating Altitude (m)	3000
Grid disconnect	Integrated 2 pole 40A MCB	Cooling	Nature Convection
AC Output Data (Back-up)		Noise (dB)	<25
Nominal Output Apparent Power (VA)	4600	User Interface	LED & APP
Nominal Output Current (A)	20	Communication with BMS	CAN
Peak Output Apparent Power (VA)**	6900 (10 seconds maximum)	Communication with Meter	RS485
Nominal Output Voltage (V)	230 (±2%)	Communication with Portal	Wi-Fi
Nominal Output Frequency (Hz)	50/60 (±0.2%)	Weight (kg)	44
Output THDv (@Linear Load)	<3%	Size (Width*Height*Depth mm)	516 X 832 X 290
Back-up Loads AC Disconnect	Integrated 2 pole 25A MCB	Mounting	Wall Bracket
Manual Back-up Load AC Bypass Switch	Integrated	Protection Degree	IP65
Efficiency		Standby Self-Consumption (W)	<13
Max. Efficiency	97.6%	Topology	Battery High Frequency Isolation/Solar Transformerless
European Averaged Efficiency	97.0%	Certifications & Standards	
Max. Battery to Load Efficiency	94.0%	Grid Regulation	CEI 0-21;VDE4105-AR-N
Protection		Safety Regulation	IEC/EN62109-1&2, IEC62040-1
Anti-islanding Protection	Integrated	EMC	EN61000-6-4, EN 61000-4-16, EN 61000-4-18, EN 61000-4-29
PV String Input Reverse Polarity Protection	Integrated		

*: 4600VA for VDE-AR-N4105, 5100VA for other country.

** : Can be reached only if PV and battery power is enough.

Product Strengths

Save money up to zero cost



Uninterrupted power supply, 10ms reaction

UPS

Up to 10 years warranty supported by strong bankability



Easy WiFi setup via remote APP settings



Fanless design, long lifespan



Charge battery @ off-peak price



Project Cases



International Awards and Rankings



GOODWE GOOD CHOICE

GoodWe (China)

No. 90 Zijin Rd., New District, Suzhou, 215011, China
T: +86 (0) 512 6958 2201
sales@goodwe.com (Sales)
service@goodwe.com (Service)

GoodWe (Brazil)

Rua Abelardo 45, Recife/PE, 52050-310
T: +55 81 991239286
sergio@goodwe.com
servico.br@goodwe.com

GoodWe (UK)

6 Dunhams Court, Dunhams Lane, Letchworth Garden City,
SG6 1WB UK
T: +44 (0) 333 358 3184
enquiries@goodwe.com.uk
service@goodwe.com.uk

GoodWe (Italy)

Via Cesare Braico 61, 72100 Brindisi, Italy
T: +39 338 879 38 81; +39 831 162 35 52
valter.pische@goodwe.com (sales)
operazioni@topenergy.com; goodwe@arsimp.it (service)

GoodWe (Australia)

Level 14, 380 St. Kilda Road, Melbourne,
Victoria, 3004, Australia
T: +61 (0) 3 9918 3905
sales@goodwe.com
service.au@goodwe.com

GoodWe (Spain)

Fürstenrieder Str. 279a, 81377 München, Germany
T: +34 661 584870
sales@goodwe.com (Sales)
soporte.es@goodwe.com (Service)

GoodWe (Korea)

8F Invest Korea Plaza, 7 Heoleung-ro Seocho-gu Seoul Korea (06792)
T: 82 (2) 3497 1066
sales@goodwe.com
Larry.Kim@goodwe.com

GoodWe (Germany)

Fürstenrieder Str. 279a 81377 München, Germany
T: +49 8974120210 +49 421 83570-170 (Service)
sales.de@goodwe.com
service.de@goodwe.com

GoodWe (Netherlands)

Franciscusdreef 42C, 3565AC Utrecht, the Netherlands
T: +31 (0) 30 737 1140
sales@goodwe.com
service.nl@goodwe.com

GoodWe (India)

1202, G-Square Business Park, Sector 30A, Opp. Sanpada Railway
Stn., Vashi, Navi Mumbai- 400703
T: +91 (0) 2249746788
sales@goodwe.com
service.in@goodwe.com

GoodWe (Turkey)

Adalet Mah. Megapol Tower K: 9 No: 110 Bayraklı - Izmir
T: +90 (232) 935 68 18
info@goodwe.com.tr
service@goodwe.com.tr

GoodWe (Mexico)

Oswaldo Sanchez Norte 3615, Col. Hidalgo, Monterrey, Nuevo Leon,
Mexico, C.P. 64290
T: +52 1 81 2871 2871
sales@goodwe.com
soporte.latam@goodwe.com

GoodWe (Portugal)

Fürstenrieder Str. 279a, 81377 München, Germany
T: +34 661 584870
sales@goodwe.com (Sales)
servico.pt@goodwe.com (Service)

GoodWe (South Africa)

Fürstenrieder Str. 279a, 81377 München, Germany
T: +27 60 719 2956
sales.africa@goodwe.com (Sales)
service.africa@goodwe.com (Service)

Note: The technical data above mentioned may be modified in order to reflect the continuous technical innovation and the improvements achieved by GoodWe's R & D team. GoodWe has the sole right to make such modification at any time without further notice. The GoodWe's customers have the right to request the latest version of the GoodWe products data sheets and all the commercial contracts that may be signed will be based on the most recent version of the data sheet at the moment of signing the contract.

Copyright © GoodWe Power Supply Technology Co., Ltd. 2019. All rights reserved.
No part of this document may be reproduced or transmitted in any form or by any means without prior written consent of GoodWe Power Supply Technology Co., Ltd.

www.goodwe.com